



NETAJI SUBHAS OPEN UNIVERSITY
Choice Based Credit System
(CBCS)

SELF LEARNING MATERIAL

HGR
GEOGRAPHY

CC-GR-01

Under Graduate Degree Programme

PREFACE

In a bid to standardize higher education in the country, the University Grants Commission (UGC) has introduced Choice Based Credit System (CBCS) based on five types of courses viz. *core, discipline specific, generic elective, ability and skill enhancement* for graduate students of all programmes at Honours level. This brings in the semester pattern, which finds efficacy in sync with credit system, credit transfer, comprehensive continuous assessments and a graded pattern of evaluation. The objective is to offer learners ample flexibility to choose from a wide gamut of courses, as also to provide them lateral mobility between various educational institutions in the country where they can carry their acquired credits. I am happy to note that the university has been recently accredited by National Assessment and Accreditation Council of India (NAAC) with grade ‘‘A’’.

UGC (Open and Distance Learning Programmes and Online Programmes) Regulations, 2020 have mandated compliance with CBCS for UGC 2020 programmes for all the HEIs in this mode. Welcoming this paradigm shift in higher education, Netaji Subhas Open University (NSOU) has resolved to adopt CBCS from the academic session 2021-22 at the Under Graduate Degree Programme level. The present syllabus, framed in the spirit of syllabi recommended by UGC, lays due stress on all aspects envisaged in the curricular framework of the apex body on higher education. It will be imparted to learners over the six semesters of the Programme.

Self Learning Materials (SLMs) are the mainstay of Student Support Services (SSS) of an Open University. From a logistic point of view, NSOU has embarked upon CBCS presently with SLMs in English / Bengali. Eventually, the English version SLMs will be translated into Bengali too, for the benefit of learners. As always, all of our teaching faculties contributed in this process. In addition to this we have also requisitioned the services of best academics in each domain in preparation of the new SLMs. I am sure they will be of commendable academic support. We look forward to proactive feedback from all stakeholders who will participate in the teaching-learning based on these study materials. It has been a very challenging task well executed, and I congratulate all concerned in the preparation of these SLMs.

I wish the venture a grand success.

Professor (Dr.) Subha Sankar Sarkar
Vice-Chancellor

Netaji Subhas Open University
Under Graduate Degree Programme
Choice Based Credit System (CBCS)
Subject : Honours in Geography (HGR)
Course : Cartographic Techniques Lab & Thematic Mapping and Surveying Lab
Course Code : CC-GR-01

First Print : November, 2021

Printed in accordance with the regulations of the Distance Education Bureau of the
University Grants Commission.

Netaji Subhas Open University
Under Graduate Degree Programme
Choice Based Credit System (CBCS)
Subject : Honours in Geography (HGR)
Course : Cartographic Techniques Lab & Thematic Mapping
and Surveying Lab
Course Code : CC-GR-01

: Board of Studies :
Members

Professor Kajal De
(Chairperson)
Director, School of Sciences
NSOU

Professor Apurba Rabi Ghosh
Retd. Professor of Geography
University of Calcutta

Ms. Tinki Kar Bhattacharya
Assistant Professor of Geography
NSOU

Professor Kanan Chatterjee
Retd. Professor of Geography
University of Calcutta

Dr. Biraj Kanti Mondal
Assistant Professor of Geography
NSOU

Dr. Sriparna Basu
Associate Professor of Geography
Sibnath Sastri College

Dr. Jayanta Deb Biswas
Retd. Associate Professor of Geography
Ashutosh College

Dr. Asitendu Roychowdhury
Retd. Associate Professor of Geography
Bhairab Ganguly College

: Course Writer :

Professor Ashis Sarkar
Retd. Professor of Geography
Chandannagar Govt. College

: Course Editor :

Professor Apurba Rabi Ghosh
Retd. Professor of Geography
University of Calcutta

: Format Editor :

Ms. Tinki Kar Bhattacharya
Assistant Professor of Geography
Netaji Subhas Open University

Notification

All rights reserved. No part of this study material may be reproduced in any form without permission in writing from Netaji Subhas Open University.

Kishore Sengupta
Registrar



**Netaji Subhas
Open University**

**UG : Geography
(HGR)**

**Course : Cartographic Techniques Lab & Thematic Mapping
and Surveying Lab**

Course Code : CC-GR-01

Unit - 1	□ Scales and their construction : Linear, Diagonal and Vernier	7 - 17
Unit - 2	□ Projections and their construction : Polar Zenithal Stereographic, Simple Conic with One Standard Parallel, Bonne's, Cylindrical Equal Area and Mercator's	18 - 36
Unit - 3	□ Diagrammatic Representation of Data : Line and Bar	37 - 45
Unit - 4	□ Representation of Point Data: Isopleths	46 - 48
Unit - 5	□ Representation of Area Data : Dots and Choropleth	49 - 55
Unit - 6	□ Preparation of Thematic Maps : Proportional Squares, Proportional Pie Diagrams, Dots and Spheres	56 - 65

Unit - 7	□ Traverse Survey using Prismatic Compass	66 - 76
Unit - 8	□ Levelling and Contouring using Dumpy Level and Prismatic Compass	77 - 102

Unit-1 □ Scales and their Construction : Linear, Diagonal and Vernier

Structure

1.0 Objectives

1.1 Introduction

1.2 Statement Scale

1.3 Ratio Scale

1.4 Graphical Scale

1.5 Construction of Graphical Scales

1.6 Comparative Scale

1.7 Vernier Scale

1.8 Construction of 'Single Positive Vernier Scale'

1.9 Summary

1.0 Objectives

- To know about the different types of scale
 - To learn about the construction of scales
-

1.1 Introduction

A map is a graphic representation of the features on the earth's surface. It is, therefore, a storehouse of spatial information. It is used to evaluate the topologic and metric properties of the geographic features, e.g., distance, direction, connectivity and proximity. These attributes enable us to identify the spatial patterns of association of the geographical features. Thus, a map conveys two fundamental properties-

a. locations and

b. attributes at locations

Therefore, map is a very powerful tool for the spatial scientists, especially geographers. Essentially maps bear a definite relationship between what has been represented on it and what exists on the surface of the earth. This relationship forms the fundamental basis for the concept of a map scale. Map scale is defined as the ratio between a distance measured on the map, or map distance (D_m) and the corresponding distance on the ground, or ground distance (D_g). Hence, a map.

$$\text{Scale} = 1 : \frac{D_g}{D_m}$$

Map scales are represented in three basic forms-

1. a statement (called, statement scale)
2. a numeric ratio (called, ratio scale or representative fraction or RF)
3. a graph (graphical scale).

i) Statement Scale 1 cm to 10 km

ii) Ratio Scale 1:1,000,000

iii) Graphical Scale

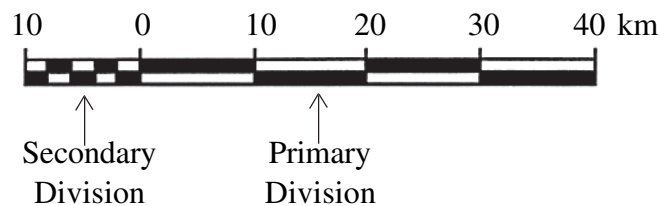

On maps it is customary to show a map scale in all the three forms for the sake of the convenience of the user. It is normally placed within a box. The location of the scale box depends on the page layout, the best cartographic presentation being decided by-page border, location, size and shape of the outline map, available space, map index, key or legends.

1.2 Statement Scale

It is a simple statement, in which the map distance is always expressed as a unit length. For example, 1 cm to 25 km or 1 inch to 50 miles. The value on the left-hand side of the statement indicates the map distance (cm/inch) and that on the right-hand side indicates the ground distance (km/mile).

Despite its simplicity, the statement scale has two demerits. First, a layman, ignorant of the various scales of measurements, will not be able to read the map. Second, a reproduction of the original map by reduction or enlargement necessitates a determination of the scale all over again.

1.3 Ratio Scale

It is a numeric ratio, in which the numerator is the map distance and the denominator is the corresponding ground distance, both being expressed in the same unit of measurement. Therefore, it is a dimensionless fraction.

For example, 1:100,000 (i.e., 1 unit of length on map is equivalent to 100,000 unit of length on ground).

The greatest advantage of a numeric ratio scale is that a map with a given R.F. can be used universally. A statement scale or a graphical scale in any system of measurement can easily be computed from the R.F. and cartographically plotted as well.

Thus, 1 : 100,000 may be written as: **1 cm to 100,000 cm** (CGS system)

or, 1 cm to $(100,000 \div 100,000)$ km

or, **1 cm to 1 km**

Similarly, 1 : 100,000 may also be written as:

1 inch to 100,000 inch (FPS system)

or, 1 inch to $(100,000 \div 63,360)$ miles

or, **1 inch to 1.58 miles**

Note:

- i. In R.F. conversion, both sides of the statement are expressed in the same unit of measurement.
- ii. The denominator of the R.F. should be rounded off to the nearest hundred or thousand or million as applicable.

1.4 Graphical Scale

A map scale may also be cartographically represented by a line or a linear graph. This is known as a graphical scale. Primarily, a straight line is divided into a number of equal parts- known as the primary divisions. The left-most primary division is then subdivided into a number of equal parts, called secondary divisions. The value of one secondary division defines the precision of the map scale. A graphical scale can be constructed from either a statement scale or a numeric ratio scale. It can then be conveniently used by a layman to measure distances on a map. The graphical scale may take four different forms-

1. a **plain** scale,
2. a **comparative** scale,

3. a **diagonal** scale and
4. a **vernier** scale.

1.5 Construction of Graphical Scales

Plain Scale

This is the simplest form of a graphical scale and is shown as a linear graph. It is also called, linear scale.

The primary or fundamental divisions (at least three) represent generally the ground distance in multiples of 1,5 or 10. The primary division on the extreme left is subdivided into a suitable number of secondary divisions. The length of each secondary division depends on the fractional length up to which precision in measurement is desired. The steps are:

1. As a construction principle, the map distance for each primary division is first evaluated from either a statement scale or R.F.
2. A straight line is drawn horizontally with a length suitable for the map (convenient class-room size being 6 inch or 15 cm).
3. With the help of a divider and a diagonal scale, primary divisions are cut off and perpendicular straight lines (of 0.5 cm or 0.3 inch) are drawn at each division point. However, primary divisions can also be made graphically.
4. The first primary division from the left is then graphically subdivided into secondary divisions with the desired precision. The drawing is then properly labelled and bordered.

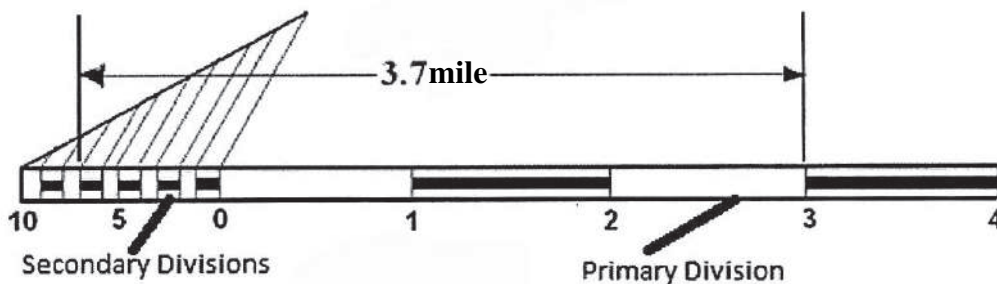

Fig. 1 Scale–1 inch to a mile

Example:

Q. Draw a Plain Linear Scale based on the statement, 1 inch to a mile.

1. Step - 1: Draw a horizontal straight line (5 inch).
2. Step - 2: Based on the statement, let the value of a 'primary division' be 1 mile.
Therefore, number of 'primary divisions' = 5.
3. Step - 3: Divide the straight line graphically or by measurements into 5 equal divisions.
4. Step - 4: Mark and label the 'primary divisions' taking 0 on the 2nd tick mark from the left.
5. Step - 5: Now, similarly divide the left-most 'primary division' into 10 equal divisions.
6. Step - 6: Mark and label the 'secondary divisions' properly (Fig. 1)

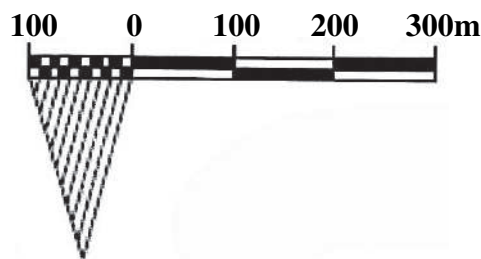

Fig. 2

Q. Draw a Plain Linear Scale based on the R.F. 1:7,500

Let the value of a 'primary division' = 100 m

Therefore, 100 m on ground is represented by 1.33 cm on map

Follow the given steps for drawing.

1. Step - 1: Draw a horizontal straight line. $(1.33 \times 4 \text{ cm}) = 5.32 \text{ cm}$
2. Step - 2: Divide the straight line graphically into 4 equal divisions.
3. Step - 3: Mark and label the 'primary divisions' taking 0 on the 2nd tick mark from the left.

4. Step - 5: Now, similarly divide the left-most 'primary division' into 10 equal divisions (depending on the degree of precision intended).
5. Step - 6: Mark and label the 'secondary divisions' properly (Fig. 2)

1.6 Comparative Scale

It is a composite linear scale in which two different linear scales representing different units of measurement, or time and distance, or pace and distance, or revolution and distance are superimposed for the sole purpose of comparison by keeping the 'O' mark same. They are respectively known as *Unit Scale*, *Time Scale*, *Pace Scale* and *Revolution Scale*.

The Unit Comparative scale is the simplest one. It shows a comparison of distance measured in different but comparable units, e.g., kilometres-miles, metres-yards, etc. The two basic principles of construction are:

- 1) in both the scales, the ground distance equivalents of the primary and the secondary divisions are identical, and
- 2) the zero marks of both the scales coincide during superimposition.

Example:

Q. Draw a Comparative Scale based on the R.F. 1 : 66,000,000.

Based on this R.F., let the value of a 'primary division' = 1000 km and 1000 miles. The map value corresponding to 1000 km and 1000 miles should be found out first.

CGS System

66,000,000 cm on ground is represented by 1 cm on map.

Or, $\frac{66,000,000}{100,000}$ km on ground is represented by 1 cm on map

Or, **1000 km** on ground is represented by $\frac{100,000 \times 1000}{66,000,000}$ cm on map
= 1.51 cm

FPS System

66,000,000 inch on ground is represented by 1 inch on map

Or, $\frac{66,000,000}{63360}$ miles on ground represented by 1 inch on map

Or, **1000 miles** on ground is represented by $\frac{63360 \times 1000}{66,000,000}$ inch on map
 = 0.96 inch

1. Step-1: Draw a 'plain linear scale' with measurements in CGS System
2. Step-2: Draw another 'plain linear scale' with measurements in FPS System just below the former, keeping 'O' mark at the same place (Fig. 3)

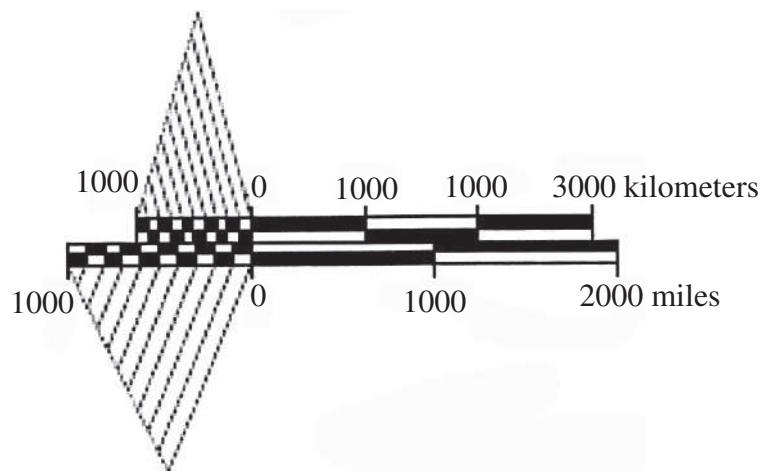

Fig. 3

Scale – 1:66,000,000

Diagonal Scale

In small and medium scale maps, accurate measurements can be obtained upto the smallest unit on the secondary division with a plain or comparative scale. However, on large scale or cadastral maps and plans (commonly used by surveyors, planners and geographers), measurements in decimal fraction are often desired, and here lies the importance and use of a diagonal scale. A diagonal scale has three types of divisions—

- 1) primary (on Main Scale),
- 2) secondary (on Main Scale) and
- 3) tertiary (on diagonal divisions).

The principle is that the total value of all 'tertiary' divisions is equal to the value of 1 secondary division. Similarly, the total value of all 'secondary' divisions is exactly equal to the value of 1 primary division. The principle of construction is based on the properties of similar triangles explained below:

Any reading which can be split into dimensionally related primary, secondary and tertiary divisions can be precisely measured with a diagonal scale.

Concept of Diagonal Scale

- At end B of line AB, draw a perpendicular.
- Step-off ten equal divisions of any length along the perpendicular starting from B and ending at C.
- Number the division points 9,8,7, 1.
- Join A with C.
- Through the points 1, 2, 3, etc., draw lines parallel to AB and cutting AC at 1', 2', 3', etc.
- Since the triangles are similar; $1'1 = 0.1 AB$, $2'2 = 0.2AB$, $9'9 = 0.9AB$.
- Gives divisions of a given short line AB in multiples of $1/10$ its length, e.g. $0.1AB$, $0.2AB$, $0.3AB$, etc.

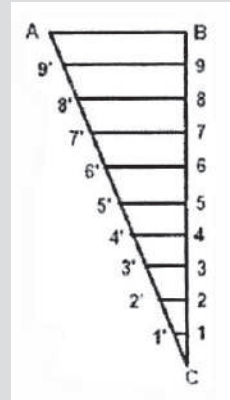

For **example**, 4.56 inch may be written as $= 4.00 + 0.50 + 0.06$

$$= (4 \times 1.00) + (5 \times 0.10) + (6 \times 0.01)$$

Here, 4, 5 and 6 are respectively the readings on the primary, secondary and tertiary divisions while their respective values are 1inch, 0.1 inch and 0.01 inch

Readings with three related units are conveniently shown on a diagonal scale. For example, kilometre-metre-centimetre, mile-furlong-yard, furlong-yard-foot, yard-foot-inch, metre-decimetre-centimetre, decimetre-centimetre-millimetre, etc. The following steps are useful for the construction of a diagonal scale:

- 1) Step - 1: Break up the reading to fix the map distances for one primary, one secondary and one tertiary division.
- 2) Step - 2: Find the magnitudes of ground distance for one primary, one secondary and one tertiary division.
- 3) Step - 3: Accordingly, find the number of primary, secondary and tertiary divisions for the scale reading to be shown.
- 4) Step - 4: First, draw a plain scale with suitable numbers of primary and secondary divisions. Tertiary divisions are then drawn perpendicularly on the leftmost division of the main scale.
- 5) Step - 5: Horizontal lines parallel to the base of the main scale are drawn through each tertiary division points.

- 6) Step - 6: Secondary divisions are then marked off on the topmost horizontal line of the leftmost primary division. These are finally joined diagonally with those at the base of the left primary division. (Fig. 4)

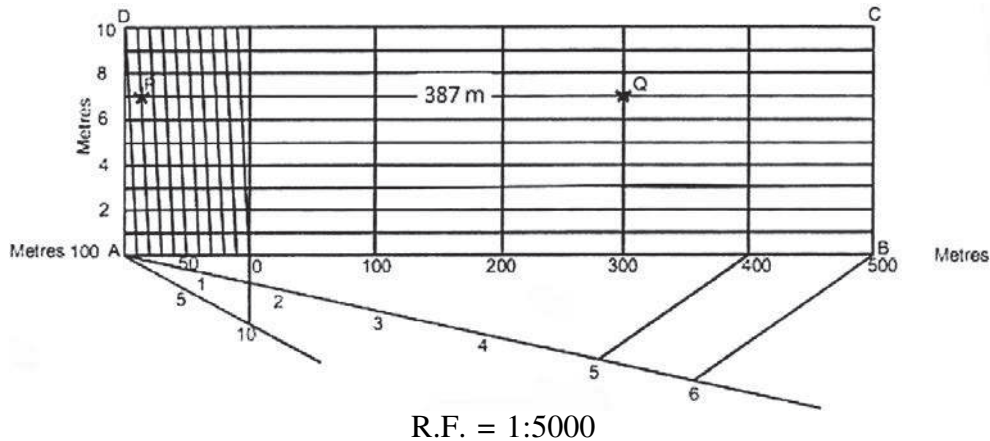

R.F. = 1:5000

Fig. 4

1.7 Vernier Scale

The vernier is a device formulated by BP Vernier by which even the fractional parts of the smallest divisions of the main scale can be measured with the highest precision. It consists of a small auxiliary scale called the vernier which moves freely with its graduated edge along a long fixed scale called the main or primary scale. The vernier carries an index mark (Fig. 5) that forms the zero of the vernier divisions and is denoted by an arrow mark. The scale may be drawn as a straight linear graph or as an arc. The device is based upon the fact that it is easier to see the exact coincidence of two lines than to judge the distance between the two lines and is used in precision instruments like theodolite, sextant, barometer, planimeter, abney level, spherometer, screw gauge, slide callipers, etc. Verniers may be of two types-single and double-depending on its construction respectively on one or both sides of the index mark. However, from the point of view of principles of construction, verniers may be divided into two classes-direct or positive and retrograde or negative.

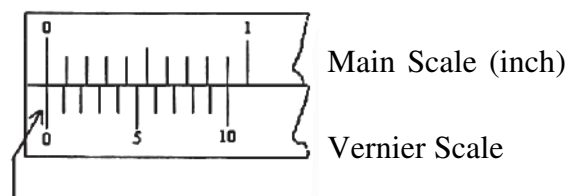

Fig. 5 : 9 main scale divisions = 10 Vernier scale divisions

1.8 Construction of 'Single Positive Vernier Scale'

In this the length of 'n' vernier divisions is equal to the length of (n – 1) main scale divisions. A vernier measurement can be decomposed into two parts as:

- 1) Main scale reading (MSR) and
- 2) Vernier reading (VR)

The VR = Vernier Constant (VC) x No. of Vernier Division that coincides with a MS division.

Vernier Constant, (VC) = The difference between the value of a main scale division and that of a vernier division

$$= \frac{1}{n}d, \text{ where } n = \text{number of vernier divisions and } d = \text{value of smallest division on the main scale. VC relates the vernier divisions with main scale division.}$$

Q. Draw a Vernier Scale to show 15.76 inch, given the value of 1 (One) smallest main scale division = 0.1 inch and 9 smallest main scale divisions are equal to 10 (ten) vernier divisions.

Therefore, the smallest main scale division = 0.1 inch

No. of vernier divisions = 10

$$\begin{aligned} \text{Vernier Constant} &= \frac{0.1}{10} \text{ inch} \\ &= 0.01 \text{ inch} \end{aligned}$$

No. of vernier division that coincides with a main scale division

$$\begin{aligned} &= \frac{\text{Measured Value} - \text{Main scale division}}{\text{Vernier constant}} \\ &= \frac{15.76 - 15.70}{0.01} = 6 \end{aligned}$$

Its construction follows these steps:

- 1) Step - 1: Break up the reading to find the values of the main scale (15.70 inch) and the vernier component (0.06 inch)

- 2) Step - 2: Calculate the Vernier Constant (0.01 inch) from the given problem and find the number of Vernier division that coincides with any of the main scale division).
- 3) Step - 3: First, draw a plain scale with a suitable number of primary and secondary divisions.
- 4) Step - 4: Based on the relations of the vernier and main scale, divide the 9 main scale division into 10 vernier scale divisions.
- 5) Step- 5: Take, on a screw-fitted divider, the length corresponding to the distance upto 6th division of Vernier scale.
- 6) Step - 6: Place one end of the divider on the main scale and slide it along the main scale until the other end coincides with a main scale division.
- 7) Step - 7: Now, mark the position of the left end of the divider on the main scale.
- 8) Step - 8: Starting from this point, draw vernier divisions (10) using a paper strip.
- 9) Step - 9: Mark and label the Vernier scale properly (Fig. 6)

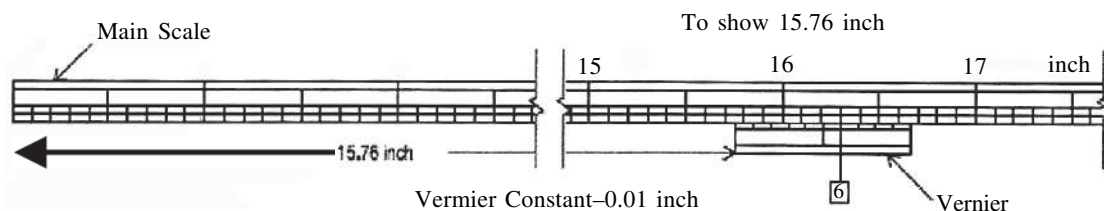

Fig. 6

1.9 Summary

From this unit we have learnt about the different types of scales and their construction. A Storehouse of spatial information and the attributes enable us to identify the spatial patterns of association of the geographical features.

Unit-2 □ Projections and their construction: Polar Zenithal Stereographic, Simple Conic with one Standard Parallel, Bonne's, Cylindrical Equal Area and Mercator's

Structure

2.0 Objectives

2.1 Introduction

2.2 Classification of Map Projections

2.3 Polar Zenithal Stereographic Projection

2.4 Simple Conical Projection with one Standard Parallel

2.5 Bonne's Projection

2.6 Cylindrical Equal-Area Projection

2.7 Construction

2.8 Mercator's Projection

2.9 Summary

2.0 Objectives

- To study about the different types of projection.
 - To learn about the construction of the projections
-

2.1 Introduction

Broadly speaking, map projection is defined as the systematic drawing of a network of parallels and meridians on a plain sheet of paper portraying a part or whole of the earth's surface. Naturally, it is scale-dependent and is done in accordance with a set of geometric and mathematical principles to satisfy certain objectives of the user. Thus, map projection is a device by which the curved surface of the earth is represented on a flat plane. The operational process essentially involves dimensional transformation, i.e., a 2-dimensional representation of the 3-dimensional figure of the earth.(Fig. 7)

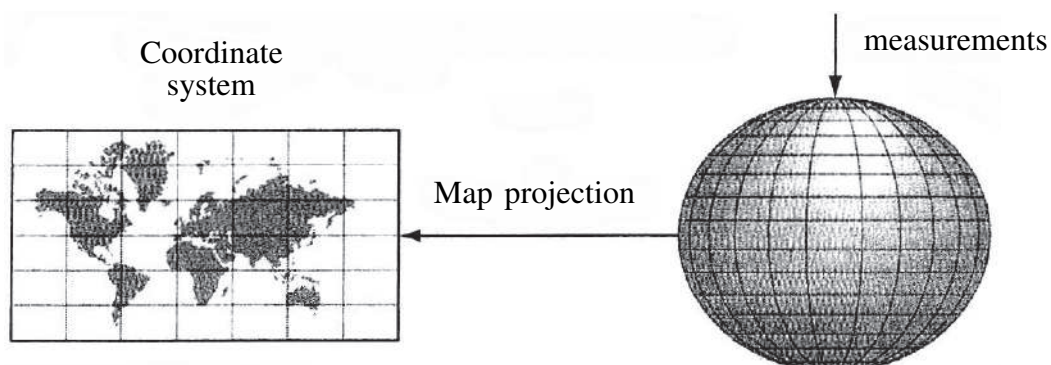

Fig. 7

Principles of Map Projection

Maps are flat, but the Earth is not. Producing a perfect map is like peeling an orange and flattening the peel without distorting a map drawn on its surface. A map projection is a mathematical model of a set of rules or for transforming locations from the 3D Earth onto a 2D display (Fig. 8). This conversion necessarily distorts some aspect of the earth's surface, such as area, shape, distance, or direction. Hence, no flat representation of the earth can be completely accurate.

Many different projections have been developed, each suited to a particular purpose. Map projections differ in the way they handle four properties: area, shape, distance and direction. Accordingly, they are called equal-area (authalic, homolographic or equivalent), orthomorphic (true-shape or conformal), equidistant, and azimuthal projections. Map projection follows certain rules.

Rules :

1. No projection can preserve all four simultaneously, although some combinations can be preserved.
2. No projection can preserve both Area and Directions. However map maker must decide which property is most important and choose a projection based on that.

Earth to Globe to Map

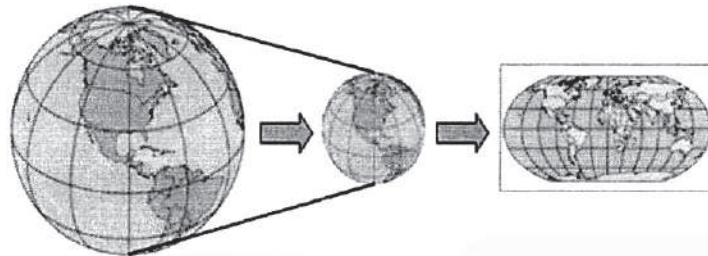

Map Scale:
Representative Fraction

$$= \frac{\textit{Globe distance}}{\textit{Earth distance}}$$

(e.g. 1:24,000)

Map Projection:
Scale Factor

$$= \frac{\textit{Map distance}}{\textit{Globe distance}}$$

(e.g. 0.9996)

Fig. 8

2.2 Classification of Map Projections

Map projections are fundamentally classified based on their extrinsic and intrinsic properties. The extrinsic properties include the exogenic parameters of transformation, i.e., the nature of datum surface, plane or surface of projection and the transformation process involved. The intrinsic properties include the specific property preserved, the geometric combination of parallels and meridians and the final shape of the graticules. Direct projection is when the projection is directly made from an oblate spheroid. Double projection is when the projection is made from a sphere originally transformed from an oblate spheroid. Based on developable surface, projections are of three types - planar (2D plane), conical (right circular cone), cylindrical (right circular cylinder) and polyhedral. Based on the tangency of projection plane, there are three types also - normal, transverse and oblique (Fig. 9). Based on the method of projection, the distinctive types are - perspective, non-perspective and conventional. Finally, based on properties the projections are of five types -

1. **azimuthal** (*direction* preserved),
2. **equidistant** (*distance* preserved),
3. **equal area** (*area preserved*: also called, **equivalent** or **authalic** or **homolographic**),
4. **orthomorphic** (*shape* preserved: also called, **conformal**) and
5. **aphylactic** (none).

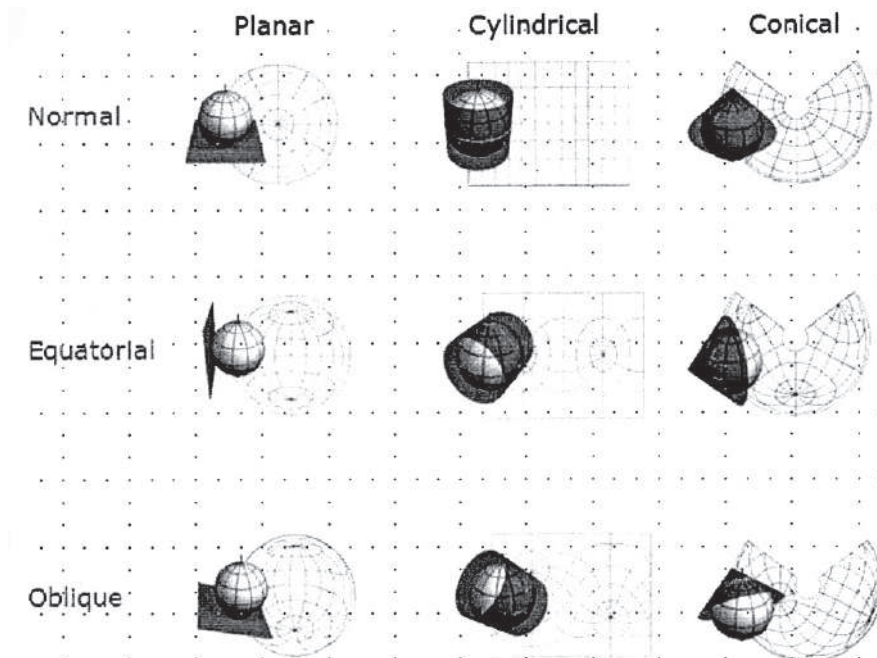

Families and Cases of Map Projection Fig. 9

2.3 Polar Zenithal Stereographic Projection

Principle

In this projection, a 2-dimensional plane of projection touches the generating globe at either of the poles. It is a perspective projection, with the source of light lying at the pole diametrically opposite to one at which the projection plane touches the generating globe (Fig.10). The parallels are projected as concentric circles of varying radius while the meridians are projected as straight lines radiating from the poles.

Theory

- 1) Radius of the generating globe,

$$R = \text{Actual radius of the earth} \div \text{Denominator of R.F.}$$

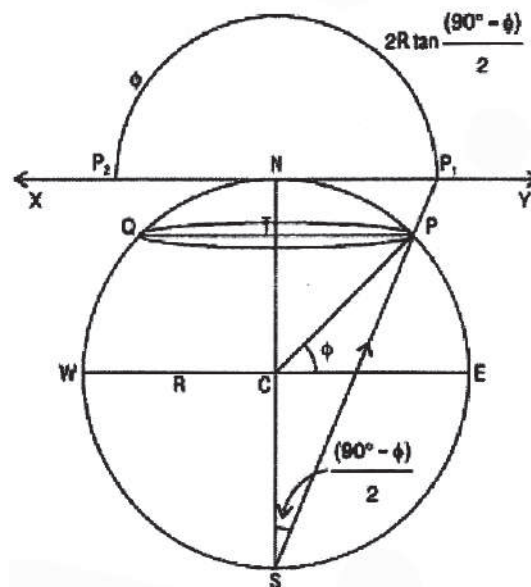

Fig. 10 : Principles of Stereographic Projection

- 2) Radius of any parallel (ϕ),

$$r = 2R \tan \frac{(90 - \phi)}{2}$$

Example

Draw the graticule on Polar Zenithal Stereographic projection for the Southern Hemisphere upto 40°S at 10° interval on R.F.-1 : 184,000,000

Computation

$$1. R = \frac{640,000,000}{184,000,000} \text{ cm} = 3.48 \text{ cm}$$

2. Radius of Parallels :

ϕ	40°S	50°S	60°S	70°S	80°S	90°S
$\frac{(90-\phi)}{2}$	25	20	15	10	5	0
R(cm)	3.48					
$r = 2R \tan \frac{(90-\phi)}{2} \text{ cm}$	3.25	2.53	1.86	1.22	0.61	0

Construction

- 1) A pair of intersecting perpendicular straight lines is drawn at the centre of the paper.

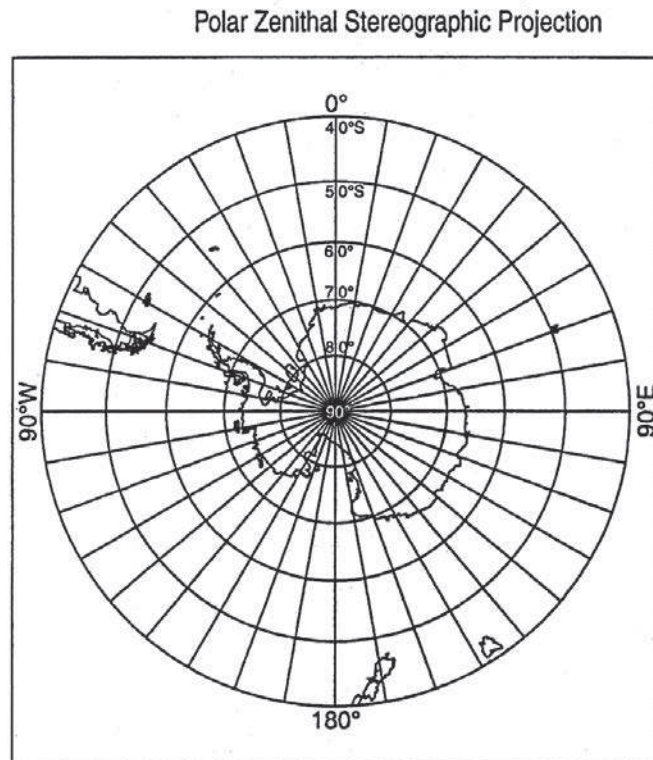

Fig. 11 Graticule on P. Z. Stereographic Projection

- 2) Concentric circles are drawn with centre at the point of intersection to represent the parallels.
- 3) With the help of a protractor, points are marked off at the given angular interval.
- 4) Straight lines are drawn joining these points with the centre to represent the meridians.
- 5) The graticule is then properly labelled with annotations. (Fig. 11)

Properties

- 1) Parallels are represented by concentric circles of varying radius.
- 2) Inter-parallel distance gradually increases toward the equator.
- 3) Meridians are straight lines radiating from the pole at true azimuth apart.
- 4) The direction between any two points is preserved.
- 5) At any point, the radial scale is equal to the tangential scale.
- 6) It is an orthomorphic projection, i.e., the shape of a map is truly preserved.
- 7) It is commonly used for the map of the world in hemispheres.

2.4 Simple Conical Projection with One Standard Parallel

Principle

In this projection, a simple right circular cone touches the generating globe along a parallel. This is the parallel along which distortions of any kind is nil and is known as the standard parallel. It is a non-perspective projection.

The standard parallel is drawn with a radius of $R \cot\phi$, where R is the radius of generating globe and ϕ is the standard parallel. Other parallels are concentric circles and meridians are radiating straight lines (Fig. 12)

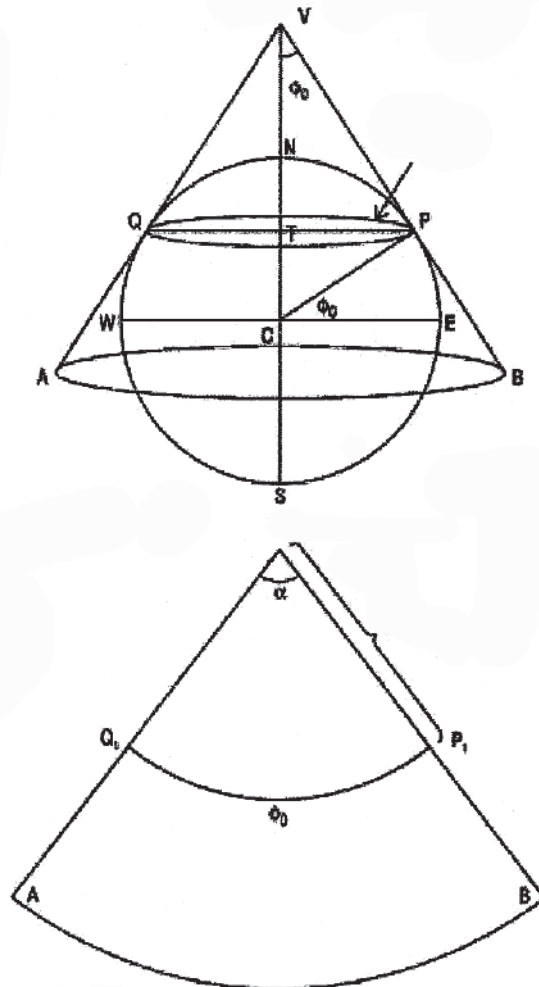

Fig. 12 : Principles of Simple Conical Projection with I Standard Parallel

Theory

- 1) The radius of the generating globe,

$$R = \text{Actual radius of the earth} \div \text{Denominator of the R.F.}$$

- 2) The division of the central meridian for spacing the parallels at i° interval, put multiplication sign but not \times .

$$d_{\text{CM}} = \frac{\pi R}{180} \times (i)$$

- 3) The radius of the standard parallel,

$$r = R \cot \varphi$$

4) The division on the standard parallel for spacing the meridians at i° interval, I .

$$\frac{2\pi R \cos \phi}{360} \times (i)$$

Example

Draw the graticule on Simple Conial projection with I Standard Parallel for the extension $20^\circ\text{N} - 60^\circ\text{S}$ and $25^\circ\text{W} - 95^\circ\text{W}$ at 10° interval on R.F. 1 : 150,000,000

Computation

$$\begin{aligned} 1. R &= \frac{640,000,000}{150,000,000} \text{ cm} \\ &= 4.266 \text{ cm} \end{aligned}$$

$$\begin{aligned} 2. d_{CM} &= \frac{\pi R}{180} \times (i) \\ &= \frac{\pi \times 4.266}{180} \times 10 \\ &= 0.744 \text{ cm} \end{aligned}$$

3. Standard Parallel between $20^\circ\text{N} - 60^\circ\text{S}$ is 20°S

$$\begin{aligned} \text{Therefore, } r &= R \cot \phi \\ &= 4.266 \cot 20^\circ \\ &= 11.72 \text{ cm} \end{aligned}$$

$$\begin{aligned} 4. d &= \frac{2\pi R \cos \phi}{360} \times (i) \\ &= \frac{2 \times \pi \times 4.266 \times \cos 20^\circ}{360} \times 10 \\ &= 0.699 \text{ cm} \end{aligned}$$

Construction

- 1) A straight line is drawn vertically through the centre of the paper to represent the central meridian.

- 2) It is then divided by d_{CM} for spacing the parallels.
- 3) An arc of circle is then drawn through the standard parallel mark with radius and centre on the central meridian (produced if necessary).
- 4) Concentric arcs of circle are then drawn through each division on the central meridian to represent other parallels.
- 5) The standard parallel is divided by d on both sides of the central meridian for spacing the meridians.

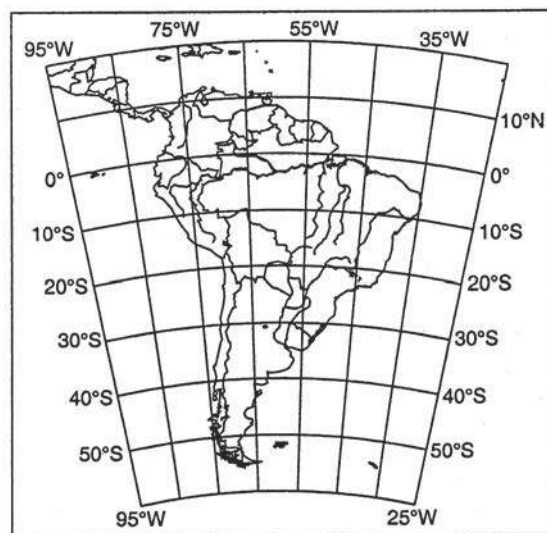

Fig. 13 : Graticule on Simple Conical Projecton with I Standard Parallel

- 6) Straight lines are drawn through each of these division points joining the centre of the arcs to represent the meridians.
- 7) The parallels and meridians are then properly labelled and annotated (Fig. 13)

Properties

- 1) It is a non-perspective projection. The parallels are concentric arcs of circles truly spaced on the central meridian.
- 2) Poles are also represented by arcs in this projection.
- 3) Radial scale is true along all the meridians.
- 4) Meridians are straight lines truly spaced on the standard parallel and converging

at the vertex of the cone.

- 5) Tangential scale is true along the standard parallel only.
- 6) Deformation is positive towards the equator-and negative towards the pole.
- 7) It is an aphyllactic projection, i.e., one that maintains neither area nor shape.
- 8) It is suitable for smaller countries of mid-latitude or temperate regions.

2.5 Bonne's Projection

Principle

In this projection, a simple right circular cone is supposed to touch the generating globe along the standard parallel. The radial scale is truly preserved along the central meridian and the tangential scale is preserved along all the parallels. Consequently, the parallels are represented as concentric arcs of circles but the meridians appear as smooth curves. This is the modification designed by R Bonne (a French cartographer) to the original Simple Conical Projection with 1 Standard Parallel(Fig. 14)

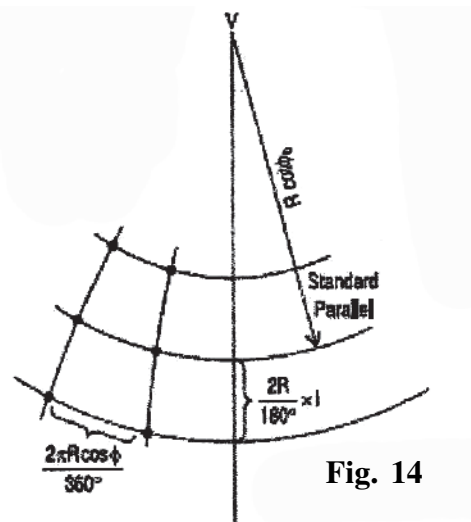

Fig. 14

Theory

- 1) Radius of the generating globe,

$$R = \text{Actual radius of the earth} \div \text{Denominator of R.F.}$$
- 2) The division of the central meridian for spacing the parallels at i^0 interval,

$$d_{CM} = \frac{\pi R}{180} x(i)$$

- 3) The radius of the standard parallel, $r = R \cot \phi$
 4) The division on the standard parallel for spacing the meridians at i° interval,

$$d = \frac{2\pi R \cos \phi}{360} \times (i)$$

Example

Draw the graticule on Bonne's projection for the extension $8^\circ\text{N} - 40^\circ\text{N}$ and $66^\circ\text{E} - 98^\circ\text{E}$ at 4° interval on R.F. 1:28,000,000

Computation

$$\begin{aligned} 1. R &= \frac{640,000,000}{28,000,000} \text{ cm} \\ &= 22.85 \text{ cm} \end{aligned}$$

$$\begin{aligned} 2. d_{CM} &= \frac{\pi R}{180} \times (i) \\ &= \frac{\pi \times 22.85}{180} \times 4^\circ \\ &= 1.59 \text{ cm} \end{aligned}$$

3. Standard Parallel between $80^\circ\text{N} - 40^\circ\text{N}$ is 24°N

$$\begin{aligned} \text{Therefore, } r &= R \cot \phi \\ &= 22.85 \cot 24^\circ \\ &= 51.32 \text{ cm} \end{aligned}$$

4. Division on Standard Parallel, $d = \frac{2\pi R \times \cos \phi}{360} \times (i)$

ϕ	8°N	12°N	16°N	20°N	24°N	28°N	32°N	36°N	40°N
R(cm)					22.85				
$d = \frac{2\pi R \cos \phi}{360} \times i$	1.57	1.56	1.53	1.49	1.45	1.40	1.35	1.29	1.22

Construction

- 1) A straight line is drawn vertically through the centre of the paper to represent the central meridian.

- 2) It is then divided by d for spacing the parallels.
- 3) An arc of circle is then drawn through the standard parallel mark with radius r and centre on the central meridian (produced if necessary).
- 4) Concentric arcs of circles are then drawn through each division on the central meridian to represent the remaining parallels.

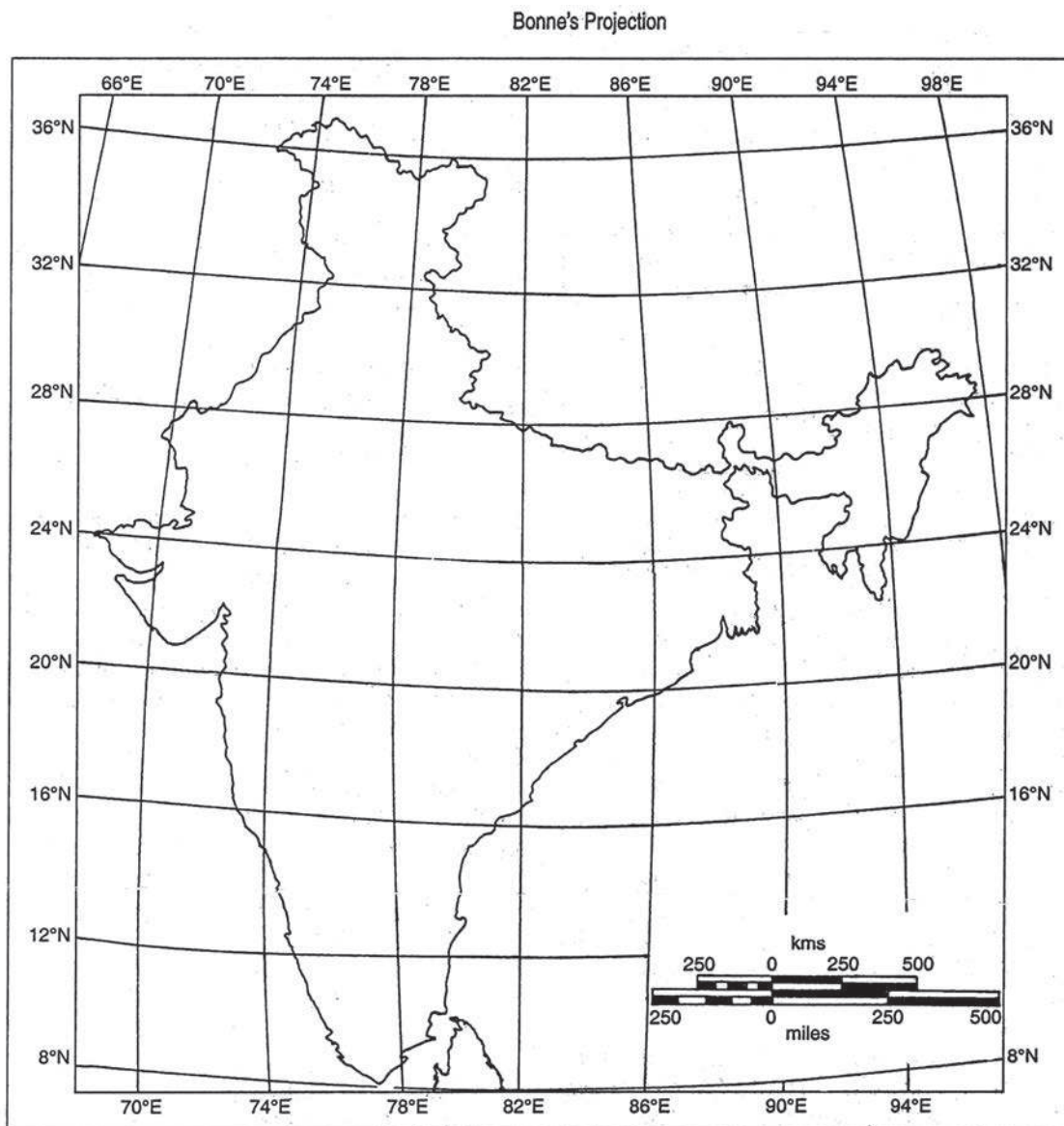

Fig. 15 Graticule on Bonne's Projection

- 5) Parallels are then divided with their corresponding division lengths on both sides of the central meridian.
- 6) Smooth free-hand curves are then drawn through the corresponding division points on the parallels to represent the meridians.
- 7) Lastly the graticule is properly labelled and annotated (Fig. 15)

Properties

- 1) Parallels are concentric arcs of circles, truly spaced on the central meridian.
- 2) Radial scale is true only along the central meridian.
- 3) The tangential scale is true along all the parallels.
- 4) Excepting the central meridian, all are regular curves concave towards the centre.
- 5) At any point the product of the two principal scales is unity.
- 6) It is an equal-area projection.
- 7) Since both parallels and meridians are curves, their intersection appears to be acute near the poles and obtuse near the lower latitudes.
- 8) For small and compact countries with nearly equal latitudinal and longitudinal extensions, angular deformation is relatively less, i.e., distortion in shape is less.
- 9) It is used for countries like France, Netherlands, Switzerland, Belgium, India, etc.

2.6 Cylindrical Equal-Area Projection

Lambert developed this projection in which a simple right circular cylinder touches the globe along the equator. Parallels and meridians are both projected as straight lines intersecting one another at right angles. Tangential scale along all the parallels is kept equal to that along the equator. To maintain true area, radial scale along a meridian is made reciprocal to the tangential scale at that point. Hence, parallels lie at different heights above the equator. The interparallel spacing decreases rapidly towards the poles as parallels are all of same length as the equator (Fig. 16)

- 1) Radius of the generating globe,

$$R = \text{Actual radius of the earth} + \text{Denominator of R.F.}$$

- 2) The division of the equator for spacing the meridians at i^0 interval,

$$d_E = \frac{2\pi R}{360} \times (i)$$

3) Height of a parallel from equator,

$$y = R \sin \phi$$

Example

Draw the graticule on Cylindrical Equal Area projection for the whole globe at 30° interval on R.F. 1 : 295,000,000

Computation

$$\begin{aligned} 1. R &= \frac{640,000,000}{295,000,000} \text{ cm} \\ &= 2.169 \text{ cm} \end{aligned}$$

$$\begin{aligned} 2. d_E &= \frac{2 \cdot \pi \cdot R}{360} \times i \\ &= \frac{2 \times \pi \times 2.169}{360} \times 30 \\ &= 1.135 \text{ cm} \end{aligned}$$

3. Height / distance of a Parallel from Equator, $y = R \sin \phi$

ϕ	30°N/s	60°N/s	90°N/s
d_E		1.135	
$y = R \sin \phi$ cm	1.084	1.878	2.169

2.7 Construction

- 1) A straight line is drawn horizontally through the centre of the paper to represent the equator.
- 2) It is then divided by d_E for spacing the meridians.
- 3) Through each of these division points, straight lines are drawn perpendicular to the equator to represent the meridians.
- 4) On the central meridian, heights of different parallels from the equator are marked.

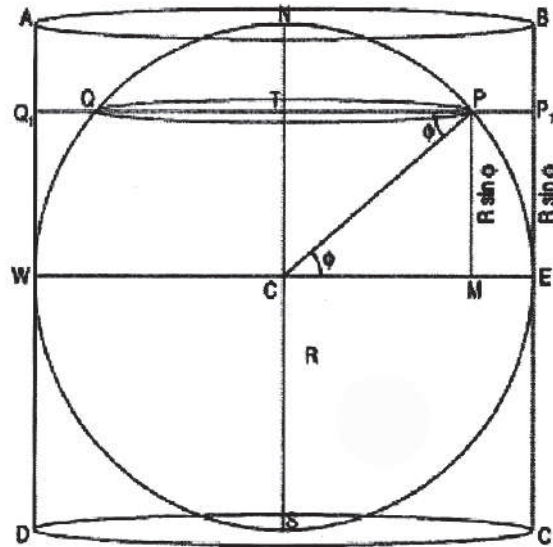

Fig. 16 : Principles of Cylindrical Equal Area Projection

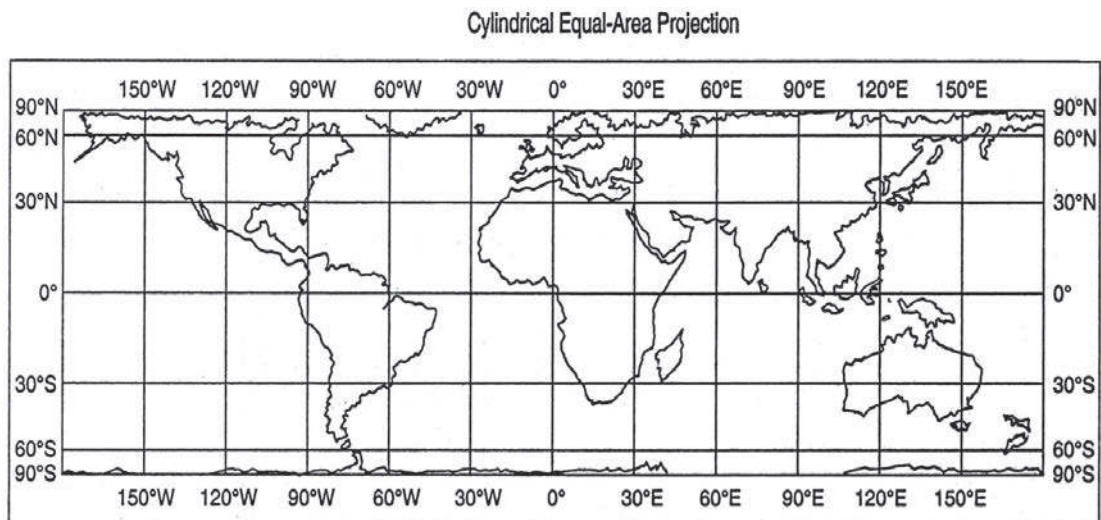

Fig. 17 Graticule on Cylindrical Equal Area Projection

- 5) Through each of these points, straight lines are drawn perpendicular to the central meridian to represent the parallels.
- 6) The graticule is then properly labelled. (Fig. 17)

Properties

- 1) Parallels are represented by a set of parallel straight lines.
- 2) Parallels are of same the length as the equator ($2nR$)
- 3) Parallels are variably spaced on the meridians.
- 4) Inter-parallel spacing decreases rapidly toward the pole.
- 5) The tangential scale rapidly increases poleward and is infinity at the poles.
- 6) Meridians are parallel straight lines truly spaced on the equator.
- 7) Meridians are of same length equal to the diameter of the globe ($2R$).
- 8) The inter-meridian spacing is uniform on all the parallels.
- 9) The pole is represented by a straight line of length $2nR$.
- 10) At any point, the product of the two principal scales is unity.
- 11) It is an equal-area projection.
- 12) The shape is largely distorted near the poles.

2.8 Mercator's Projection

Principle

This is a cylindrical orthomorphic projection designed by Mercator and Wright. In this, a simple right circular cylinder touches the globe along the equator. All the parallels are of the same length equal to that of the equator and the meridians are equispaced on the parallels. Therefore, the tangential scale increases infinitely toward the pole. To maintain the property of orthomorphism, the radial scale is made equal to the tangential scale at any point. Hence, parallels are variably spaced on the meridians and the poles can never be represented. The parallels and meridians are represented by sets of straight lines intersecting at right angles.

Theory

- 1) Radius of the generating globe, $R = \text{Actual radius of the earth} \div \text{Denominator of R.F.}$
- 2) The height of a parallel from the equator,

$$y = 2.3026R \log \tan \left(\frac{90 + \phi}{2} \right)$$

3) Divisions on the equator for spacing the meridians at i^0 interval,

$$d_E = \frac{2\pi R}{360} x(i)$$

Example

Draw the graticule on Mercator's projection for the whole globe from 80°N – 80°S at 20° interval on R.F. 1:295,000,000.

Computation

$$1. R = \frac{640,000,000}{295,000,000} \text{ cm}$$

$$= 2.169 \text{ cm}$$

$$2. d_E = \frac{2\pi R}{360} \times (i)$$

$$= \frac{2 \times \pi \times 2.169}{360} \times 20^\circ$$

$$= 0.757 \text{ cm}$$

3. Height / distance of a Parallel from Equator, $y = 2.3026R \log \tan \left(\frac{90 + \phi}{2} \right)$

ϕ	20°N/s	40°N/s	60°N/s	80°N/s
$\left(\frac{90 + \phi}{2} \right)$	55°	65°	75°	85°
R(cm)	2.169			
$y = 2.3026R \log \tan \left(\frac{90 + \phi}{2} \right) \text{ cm}$	0.772	1.655	2.856	5.284

Construction

- 1) A straight line is drawn horizontally through the centre of the paper to represent the equator.
- 2) It is then divided by d_E for spacing the meridians.
- 3) Through each of these division points, straight lines are drawn perpendicular to the equator to represent the meridians.

- 4) On the central meridian, heights of different parallels from the equator are marked.
- 5) Through each of these points, straight lines are drawn perpendicular to the central meridian to represent the parallels.

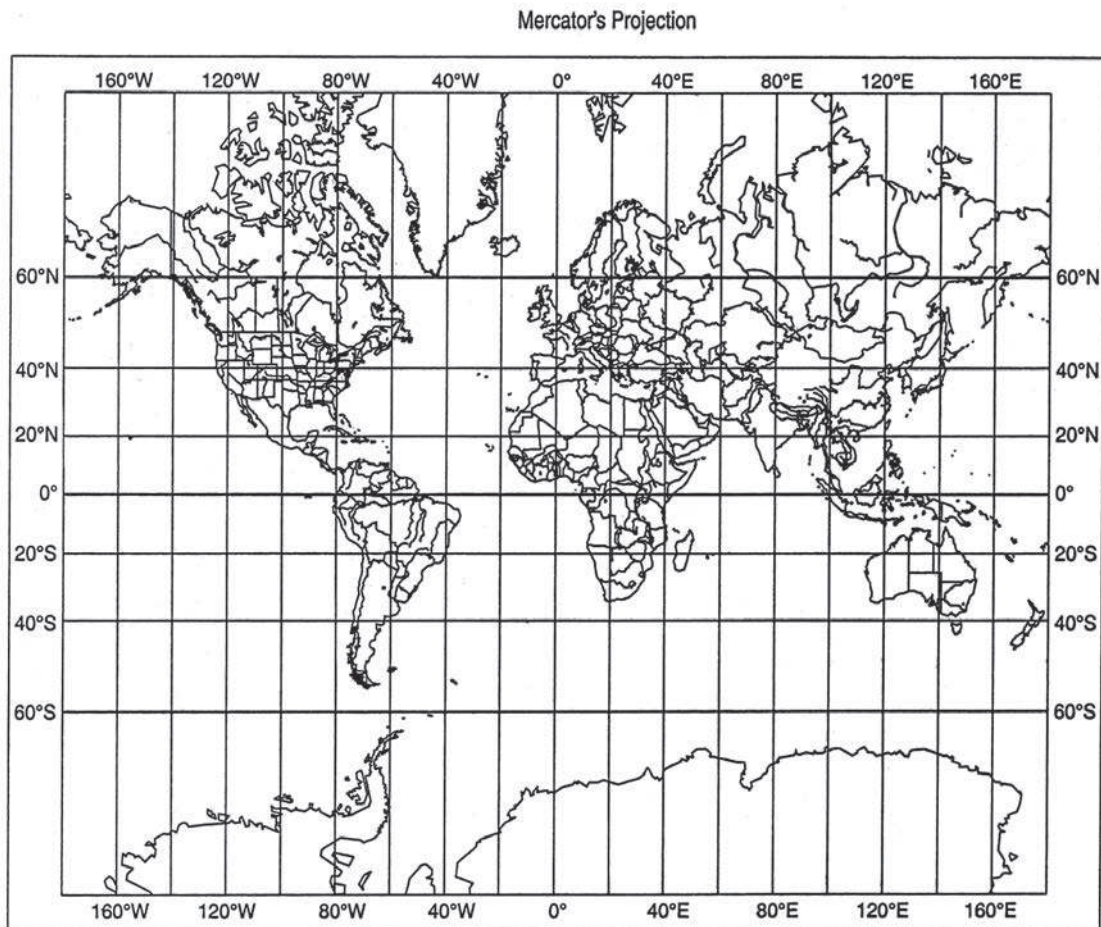

Fig.18 : Graticule on Mercator's Projection

- 6) The graticule is then properly labelled and annotated(Fig. 18)

Properties

- 1) Parallels are represented by a set of parallel straight lines.
- 2) All parallels are of same length as the equator.

- 3) Parallels are variably spaced on a meridian and inter-parallel distance increases away from the equator.
- 4) The poles cannot be represented in this projection.
- 5) Meridians are represented by a set of parallel straight lines truly spaced on the equator only.
- 6) Meridians are equispaced on all the parallels and they are of equal dimension as well.
- 7) Parallels and meridians intersect each other at right angles.
- 8) On the map, the radial and the tangential scales are identical at all points.
- 9) It is an orthomorphic projection.
- 10) Direction being preserved in this net, any straight line drawn on this projection intersects the parallels at constant angles and thus represents a line of constant bearing on the globe forming a loxodrome or rhumbline. Therefore, the bearing from one point to another can easily be found by drawing a line between them and reading off the angle it makes with the meridians. Hence, it is very useful to sailors.
- 11) It is suitable for world maps showing wind circulation patterns, ocean circulation patterns, routes, drainage patterns, etc.

2.9 Summary

Map projection is a way to flatten a globe's surface into a plane in order to make a map. It is used to portray all or part of the round Earth on a flat surface. Thus the it is a 2-dimensional representation of the 3-dimensional figure of the earth.

Unit 3 : Diagrammatic Representation of Data: Line and Bar

Structure :

3.0 Objectives

3.1 Introduction

3.2 Line Graphs

3.3 Bar Diagrams

3.0 Objectives

- To study about the diagrammatic representation
 - To learn about the tyhpes of graphs
-

3.1 Introduction

The Diagrammatic representation of data can be done by line graphs and bar diagrams.

3.2 Line Graphs

In these the points are plotted by means of rectangular coordinates with reference to a point of origin at which the x-axis (horizontal line) and y-axis (vertical line) intersect at right angles. The positive values are plotted to the right of the origin (zero) of the x-axis and above the origin (zero) of the y-axis, while the negative values are placed to the left of the origin (zero) of the x-axis and below the origin (zero) of the y-axis. Both the positive and negative values of the axes increase away from the origin.

1. Normally, period data, i.e., data on time frame and point data, i.e., spatial or vector data are represented in these graphs.
2. The chronological units are shown on the x - axis and the attributes of the variable on they - axis.
3. While plotting a curve, the vertical scale along the y - axis must be graduated from zero. However, scale-breaks can be used in demanding situations.
4. The curves must stand out clearly from the background. Therefore, it is mled more distinctively than the axes and guidelines.
5. When several curves are drawn on the same frame each should be clearly identified and distinguished by line, style or colour.
6. A line graph is normally a visual aid to understand the overall changes in value.

As it rarely represents the true locus, points should be joined by a series of short straight lines. However, smoothening may be done by applying the statistical methods of curve fitting.

A **simple** line graph represents only a single series of values connected by a curve (Fig. 19 and 20). A **polygraph** is a **multiple** line graph in which several sets of values are represented by distinctive lines for direct comparison (Fig. 21). A **band** graph is simply an aggregate or a compound line graph in which the trends of values in both the total and its constituents are shown by a series of lines on the same frame. The area between two successive lines is distinctively shaded for clarity.

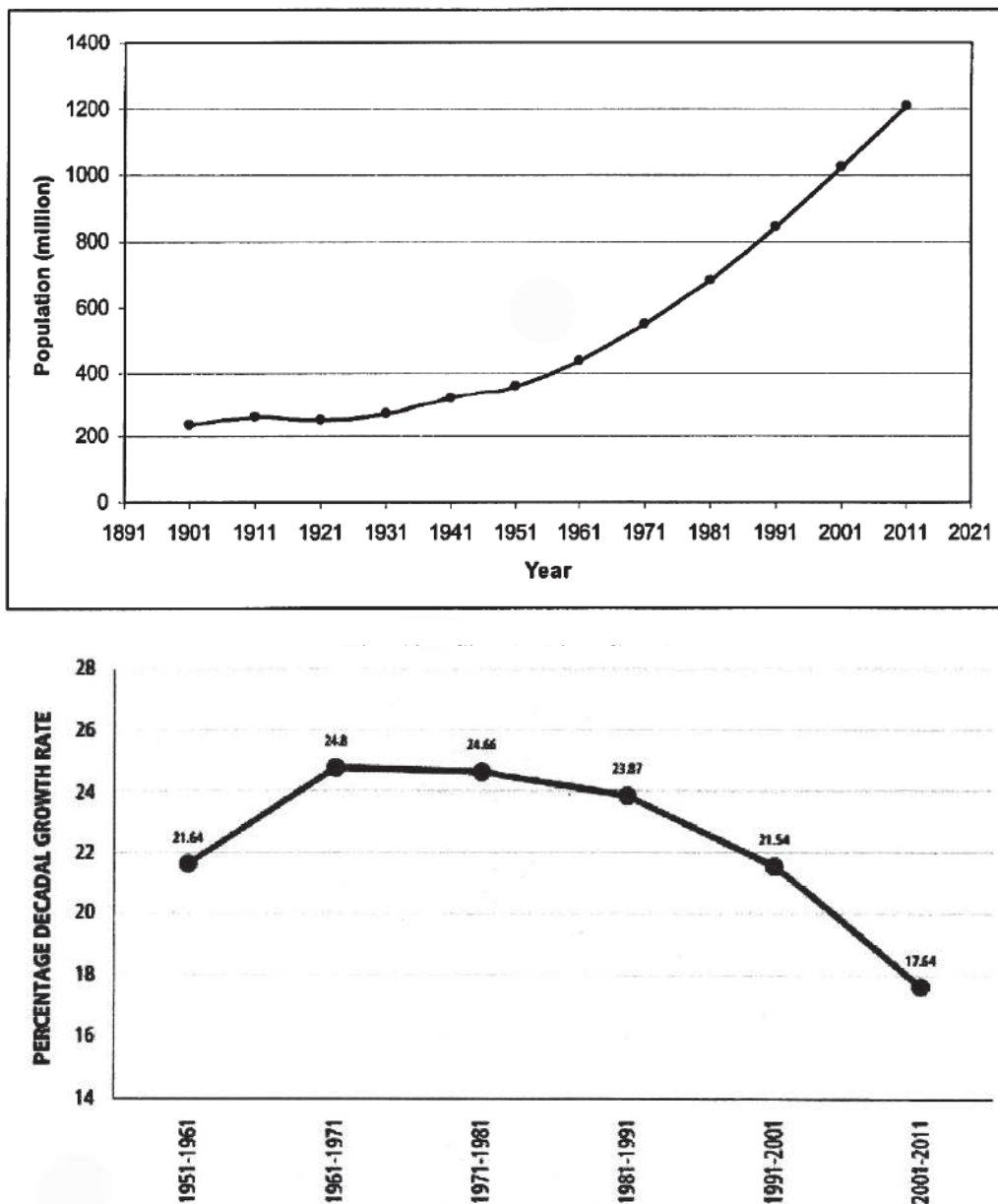

Fig. 20 : Simple Line Graph

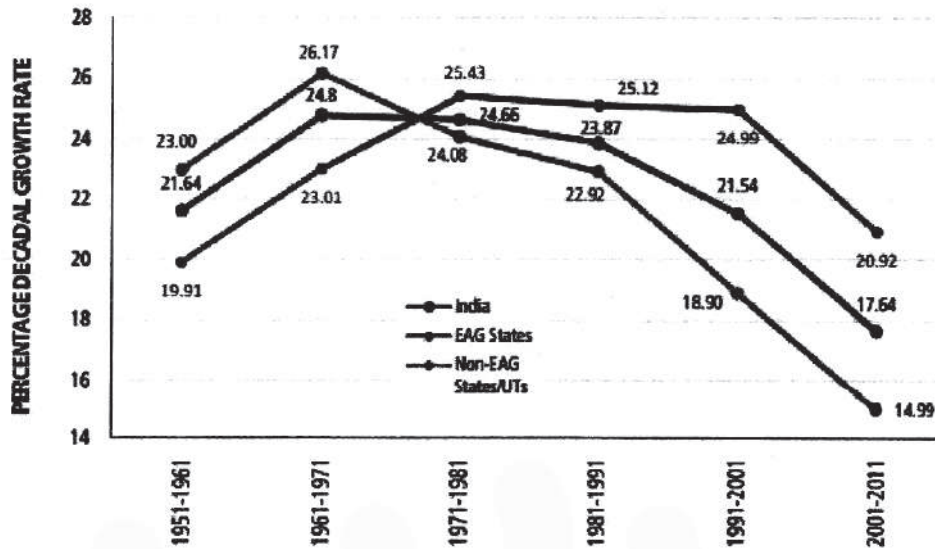

Fig. 21 : Multiple Line Graphs

Line graphs are normally drawn on an arithmetic scale, but when the range and dispersion of the data are very high, a logarithmic scale is taken. Such graphs are called **log** graphs. When logarithmic scales are taken along both the x - axis and the y - axis, the graphs are called **log-log** graphs(Fig. 22). When a logarithmic scale is taken along the y - axis and an arithmetic scale along the x - axis, they are called **semi-log** graphs(Fig. 23). These are particularly used when the variable is characterised by a very large range of values and a roughly constant ratio of increase.

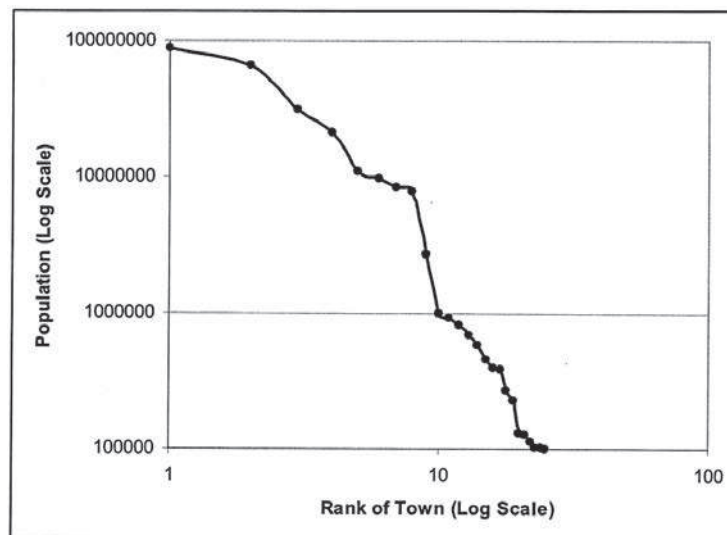

Fig. 22 : Log-log Line Graph (Rank-Size Distribution of Cities)

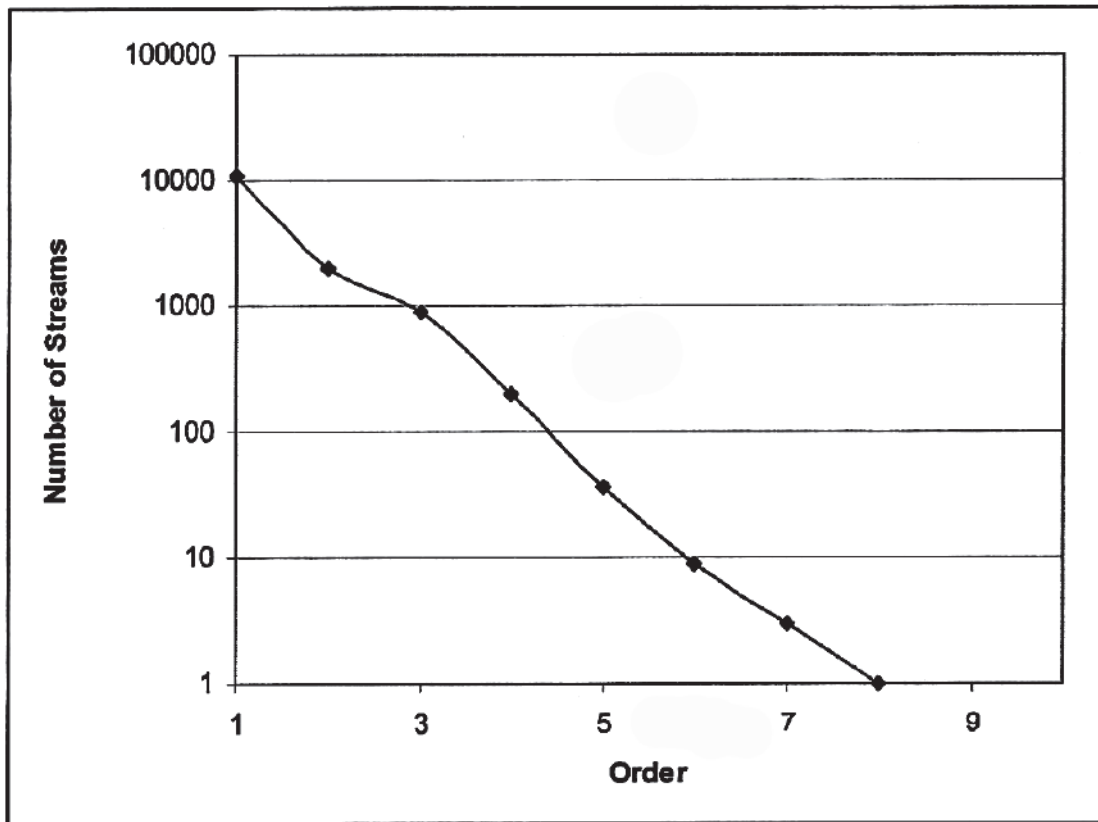

Fig. 23 : Semi-log Line Graph (Stream Order-Number relation)

3.3 Bar Diagrams

These are 1-dimensional diagrams comprising a series of columns or bars proportional in length to the quantities they represent. Genetically bar diagrams are of three types—

- 1) **simple** bar diagrams, when the data with only one component is available and each bar represents a single value(Fig. 24).
- 2) **compound** bar diagrams, when the data comprises more than one component within a total and each bar is proportionately divided to show the constituents as well as the total; hence, these are more useful for comparison(Fig. 25) and
- 3) **multiple** bar diagrams, when different bars of proportionate lengths are drawn side by side to represent the constituents(Fig. 26).

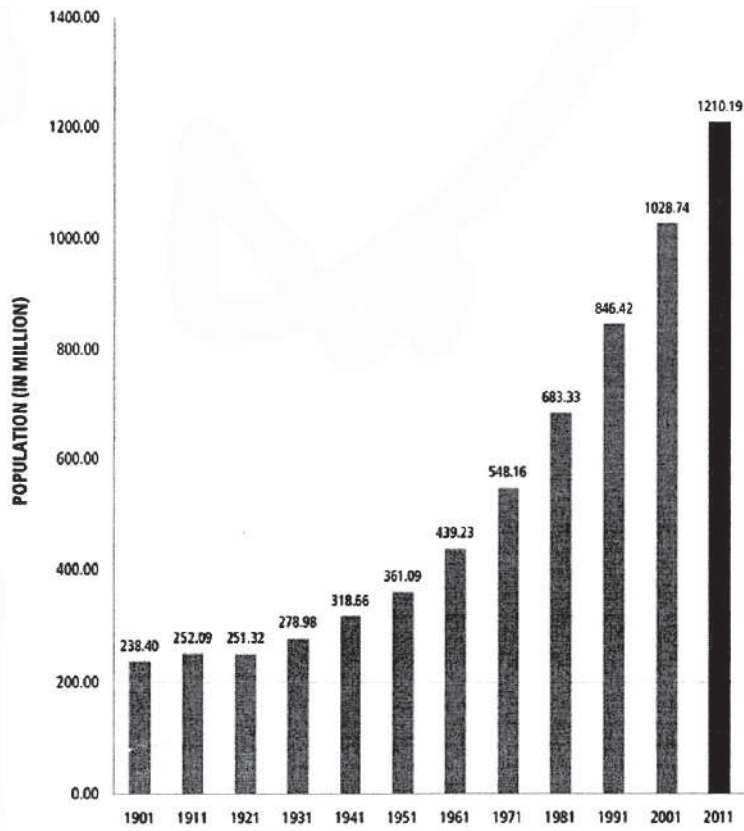

Fig. 24 : Simple Bar Diagrams

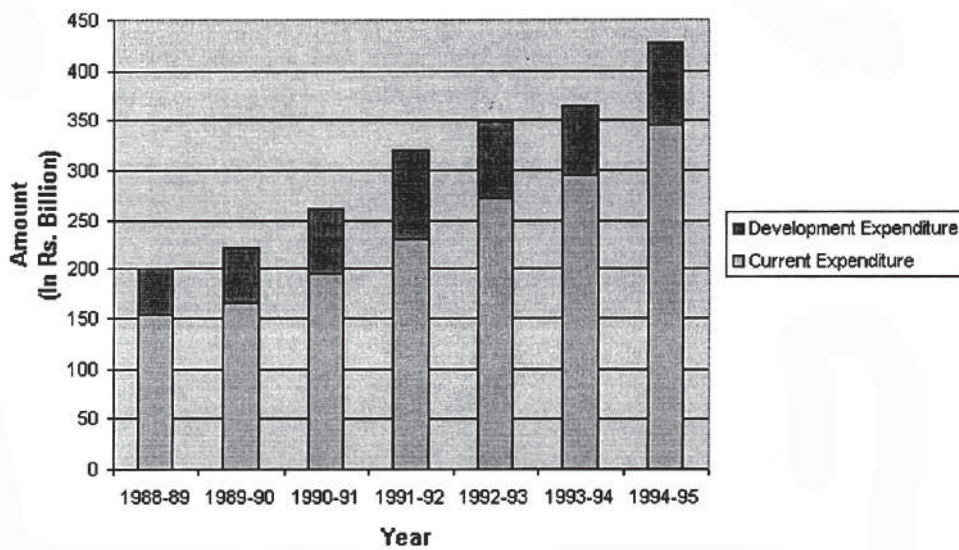

Fig. 25 : Compound Bar Diagrams

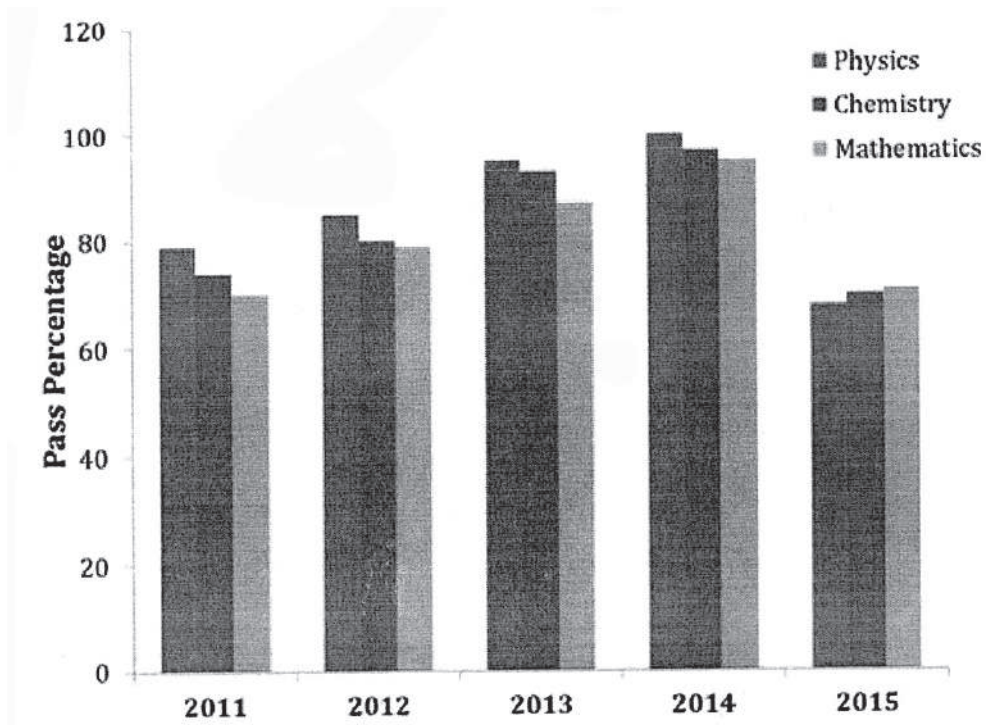

Fig. 26 : Multiple Vertical Bar Diagrams

Based on the arrangements of the columns, bar diagrams are of three types:

- i) **vertical** bar diagrams(Fig. 26), when the bars are placed vertically above the abscissa,
- ii) **horizontal** bar diagrams(Fig. 27), when the bars are placed parallel to the abscissa and
- c) **pyramidal** bar diagrams or **pyramid**(Fig. 28 & 29) when the bars are arranged in the form of a pyramid.

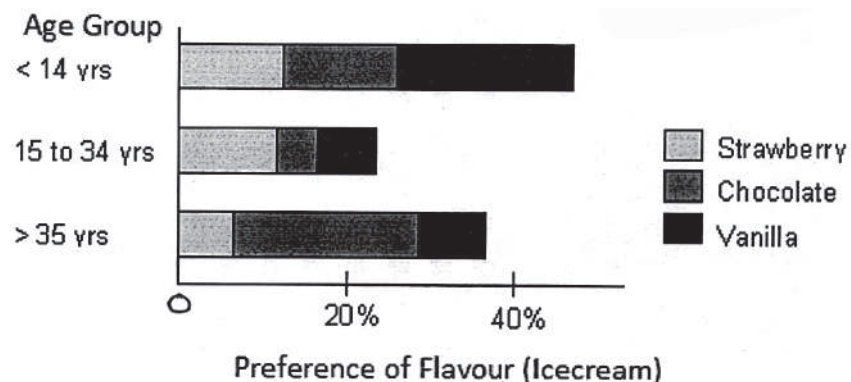

Fig. 27 : Horizontal Compound Bar Diagrams

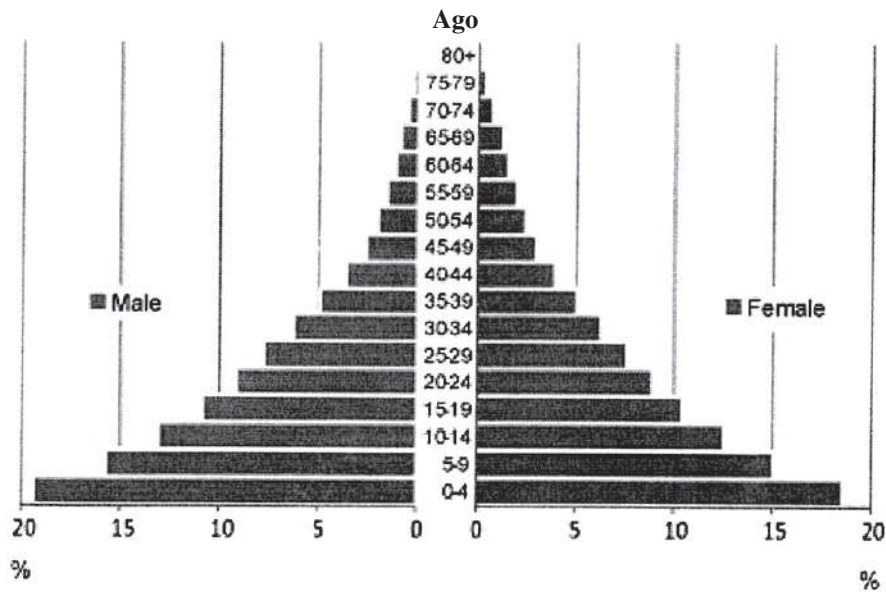

Fig. 28: Pyramid Diagrams

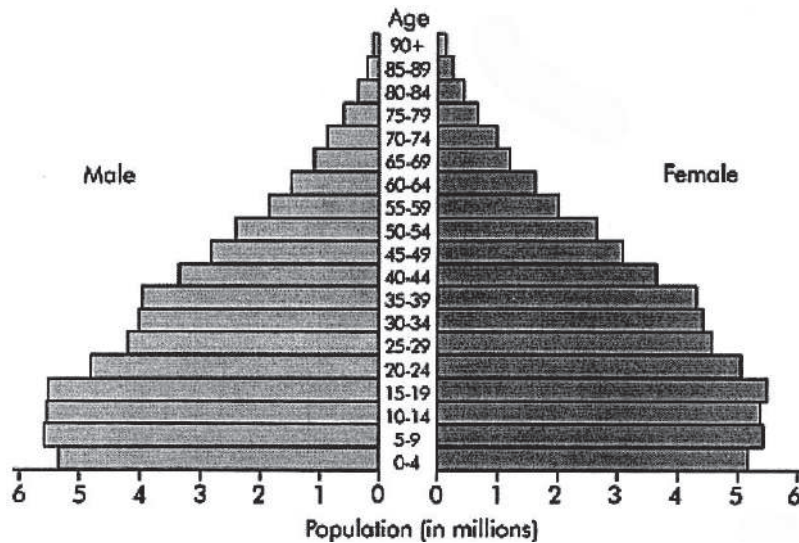

Fig. 29 : Pyramid Diagrams

Sometimes, percentage bar diagrams(Fig. 30), are drawn with the percentage values of the constituents. Such bars are of the same height representing 100% and are very useful for information about proportions. Again, to show the increase and decrease or profit and loss or surplus and deficit or positive and negative deviations, a two directional bar diagram or '**deviation** bar diagram' is drawn(Fig. 31). Here, vertical bars are drawn above and below the horizontal zero line.

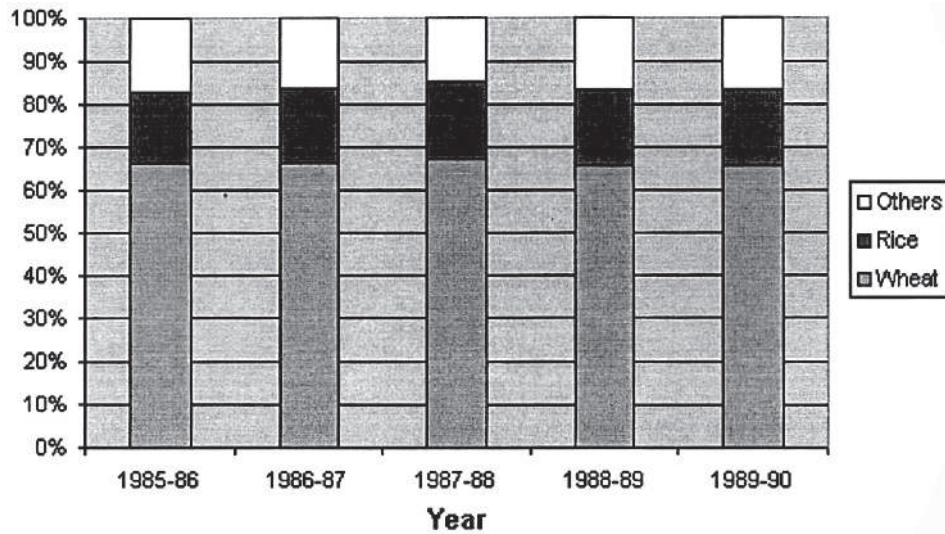

Fig. 30 : Percentage Bar Diagrams

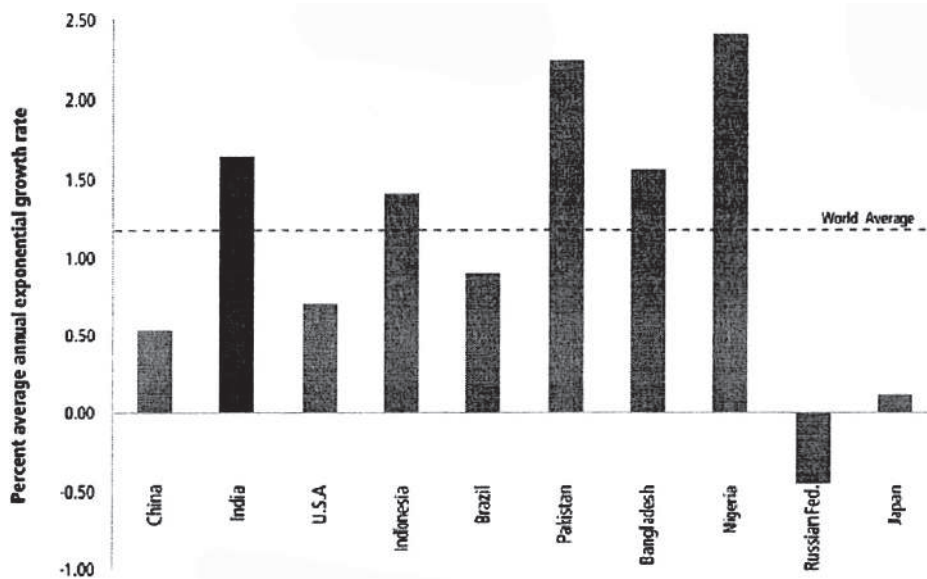

Fig. 31 : Deviation Bar Diagrams

The basic principle of bar diagrams is that the length of a bar for an item is directly proportional to the quantity of the item it represents. Therefore, a suitable bar scale is first selected through visual inspection of data (1 cm represents 10,000 units). The general rule for its construction is—

1. Prepare a Worksheet (Table-1)

2. Select a Bar Scale
3. Compute the Bar Length
4. Draw the 'bar's with the computed lengths and annotate properly.

Worksheet for Bar Diagrams

District	Population (P)	Scale (s)	Length of Bar $P/10,000(\text{cm})$
AA	54689		5.46
BB	86521		8.65
CC	9987	1 cm= 10,000	0.99
DD	24568		2.45
EE	19863		1.98

While choosing a bar scale, the ease of computation, construction and comprehensibility are of prime concern. Individual bars should be neither exceedingly short and wide nor very long and narrow. A worksheet must be drawn to show the computation in detail. An important point to remember is that the origin of the bar scale must be zero. However, space may be saved by using a scale break in some situations where there is a large range of values. Bars are separated by spaces not less than half the width of a bar or more than the width of a bar. Individual bars are essentially equal in width and uniformly spaced.

However, in rainfall diagrams and in some special cases, no intervening spaces are left giving them the appearance of a battleship. Guide lines are helpful for understanding the diagram and may be extended throughout the diagram. Colours or shades may be applied for a better visual appeal.

Unit-4 □ Representation of Point Data: Isopleth

Structure :

1.0 Objectives

4.1 Introduction

4.2 Isopleth Maps

4.3 Summary

4.0 Objectives

- To learn about the representation of point data.
 - To study about isopleth maps.
-

4.1 Introduction

These are quantitative areal maps where quantities are indicated by lines of equal value known by a multiplicity of such terms as isopleth (*iso* = equal, *plethos* = a multitude or crowd), **isarithmetic**, **isoline**, **isometric** lines, **isontic** lines and **isogram**.

4.2 Isopleth Maps

Wright (1944) proposed that isograms be used for all lines of quantity with two subdivisions—**isometric** lines (*metron* meaning measurement) that represent a constant value or intensity pertaining to every point through which it passes and **isopleths** that represent a quantity or enumeration assumed to be constant, pertaining to certain areas through which it passes.

An isopleth map (Fig. 32) is principally trend-surface map with three dimensions. The spatial trends are indicated by the spacing of isopleths. The closer the isopleths, the sharper the spatial variation and the steeper the horizontal gradient, and vice versa. Hence, regionalisation becomes easier based on the spatial geometry.

However, the precision of drawing of isopleths along with the resultant geometric pattern depends on the selected value intervals, the size and shape of the units for which statistics are available, the situation of the plotting points and the actual method of interpolation (Mackay 1953, Porter 1958).

Based on the overall range of quantities to be mapped, value intervals should be carefully selected. Intervals may be —

- (a) **isarithmetic**, i.e., on a rhythmic interval basis (e.g., common intervals in arithmetic progression—2, 4, 6, 8 ...),
- (b) **geometric** (e.g., common factors in geometric progression—2, 4, 8, 16 ...) and
- (c) based on **natural breaks** in a frequency distribution.

The size of the enumeration unit determines the frequency and density of evaluated points from which the isopleths are interpolated and hence the precision. The shape of the areal units determines the location of the plotting points. Usually areal centres or centroids are at first carefully marked and then isopleths are interpolated in them.

- 1) The principle of interpolation is based on the assumption that between any two points there is a uniform rate of change of values. Hence, the isopleths are proportionally placed.
- 2) Isopleth maps are effectively drawn with both the absolute and the indexed values of any kind of information that involves spatial variation.
- 3) For better visual appeal inter-isopleth spaces may be filled in by graded shading and colour (Fig. 33).
- 4) In case of isometric lines, the maps are called chorismeter maps while in case of isopleths the maps are called chorisopleth maps (Wright 1944).
- 5) Isopleth maps, showing spatial distribution of an element, may be prepared on different time frames for an understanding of the changes in regional pattern.

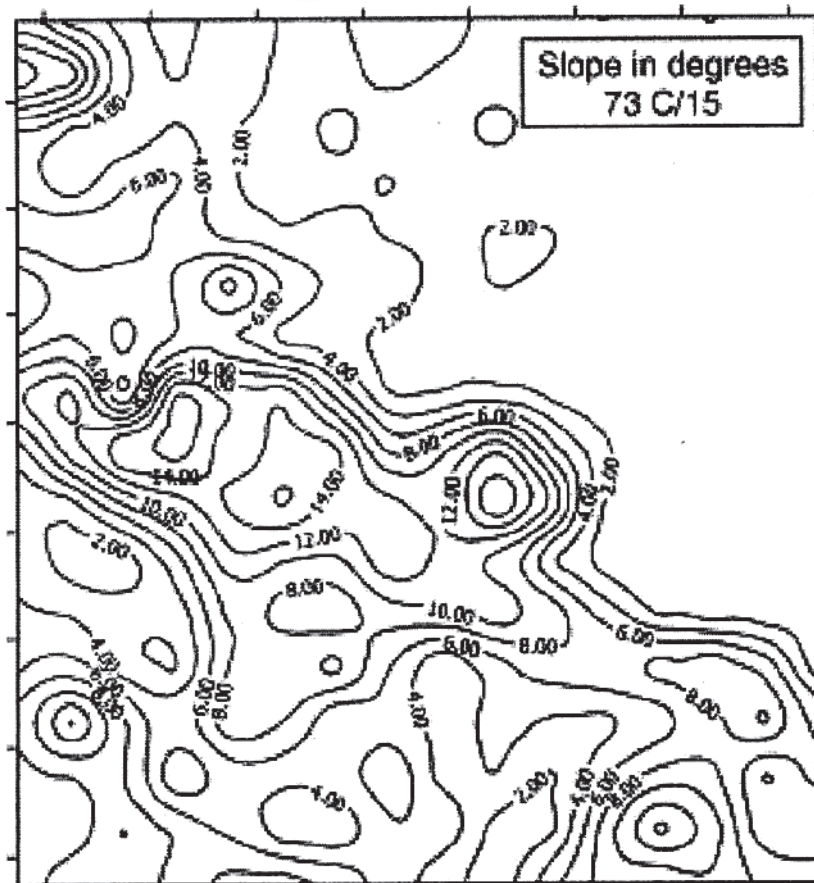

Fig. 32 : Isopleth Map

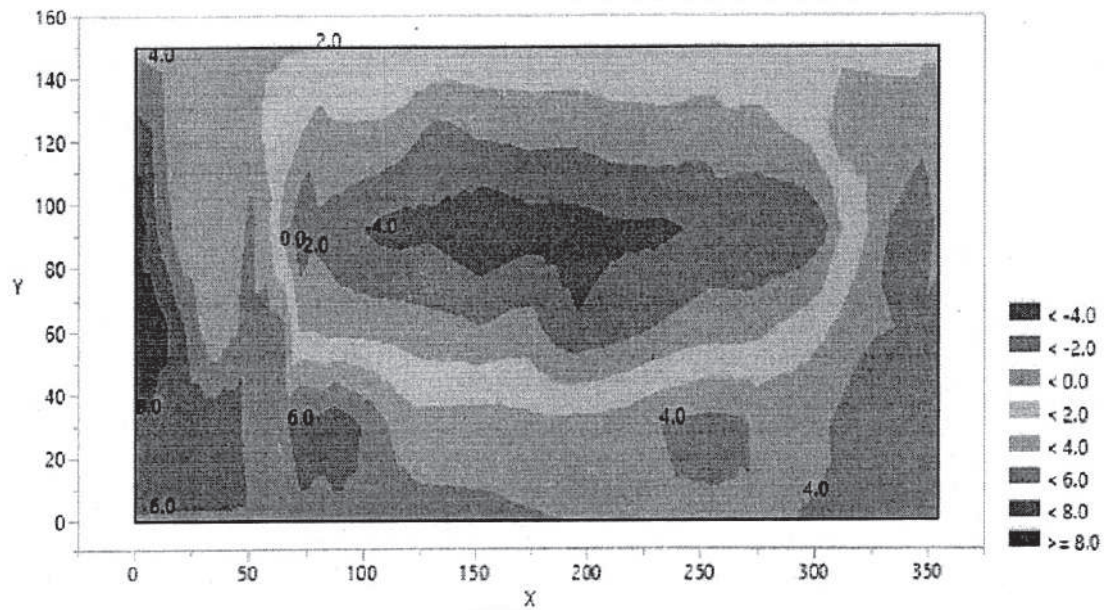

Fig. 33 : Isopleth Map

1.1 Summary

Isopleth maps are very useful for geographical representation of data and used for simplification of information about a region by showing areas with continuous distribution.

Unit-5 □ Representation of Area Data: Dots and Choropleth

Structure

5.0 Objectives

5.1 Introduction

5.2 Qualitative Dot Map

5.3 Worksheet for Quantitative Dot Map

5.4 Quantitative Dot Map

5.5 Choropleth Map

5.6 Summary

5.0 Objectives

- To study about the quantitative and qualitative maps.
- To study about the representation of these maps.

5.1 Introduction

The representation of area data for shown through dots and choropleth.

5.2 Qualitative Dot Map

These are maps in which dots are used to denote a position, the location of a feature, the intensity at a place, or a representative location for spatial summary data. Examples are a coordinate location, a radio tower, a spot height, the centroid of some distribution, or a conceptual volume at a place, such as the population of a settlement.

Naturally, mapping is done with nominal data as well as ordinal data. Even though the marks (i.e., the dots drawn in these maps as circles of different sizes) may cover some map space, they are point symbols as they conceptually refer to a location (Fig. 34) The principles are:

- (a) dot size is subjectively scaled, directly varying with the ascending order of data values and
- (b) dots are positioned and centred exactly at the map locations.

Visual variables of hue, orientation and shape can be applied to enhance the quality of map presentations as desired by the cartographer.

5.3 Worksheet for Quantitative Dot Map

Mouza	Rural Population	Scale		Dot Size (d=mm)
PP	345	Dia (mm)	Range	4
QQ	678	4	<500	8
RR	875	8	500-1000	8
SS	1345	12	1000-1500	12
TT	456			4

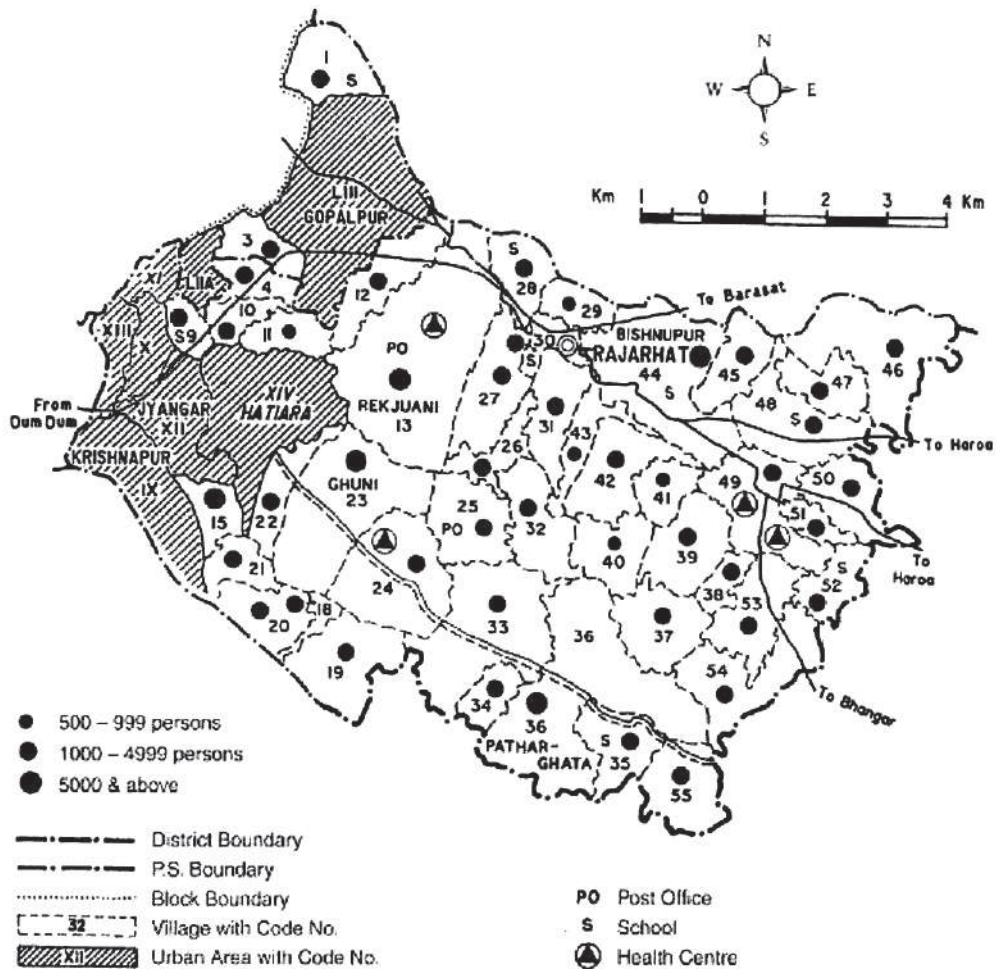

Fig. 34 : A Qualitative Dot Map

5.4 Quantitative Dot Map

In this kind of distribution maps, quantities or values are represented by dots of uniform sizes, each dot having a specific value (Winterbotham 1934) (Fig. 35). Dot maps are especially useful when the values are unevenly and sporadically distributed. The dots are inserted within the particular administrative units for which data is available. The smaller the units, the more accurate is the map.

While constructing a dot map the first step is to examine the range of quantities involved. From this, a value represented by each dot is selected. Basically, the success of a dot map depends absolutely on the choice of this value, called dot scale. It is chosen, keeping in mind the size of the administrative unit so that dots are neither numerous nor few.

According to the principle, the number of dots corresponding to an administrative unit is directly proportional to the quantity. In other words, the statement, *one dot* represents *k* quantity forms the 'dot scale'. Hence, the number of dots for any administrative unit can be easily computed by dividing the quantity with the denominator of the scale.

Worksheet for Quantitative Dot Map

District	Rural Population (P)	Dot Scale (s)	No. of Dot (P/s)
AAA	12345	1 dot = 1000	12
BBB	34567		35
CCC	9875		10
DDD	17345		17
EEE	22456		22

While plotting, the dots should be placed evenly and uniformly within each unit. The boundaries of the units are often erased after the insertion of dots. Dots should never be placed in straight rows and columns; rather the vertices of a small equilateral triangle should be assumed and dots should be placed on these. The precision of a dot map can be enhanced by consulting a physical map showing negative areas. The size of the dots depends on the scale of the base map and on the number of dots to be inserted. To avoid the effects of coarseness or blurring and to obtain a finer visual tone, a nomograph may be consulted (Mackay 1949).

Dot maps have three variants—percentage dot maps, mille dot maps and multiple dot maps. In the first two categories, the percentage values are mapped. In percentage

dot maps, each dot represents 1% while in mille dot maps each dot represents 0.1%. Such maps facilitate arithmetical comparisons and give ready information about the fractional distributions and proportions. In multiple dot maps, the distribution of several elements are normally shown using dots of differing colours and sizes.

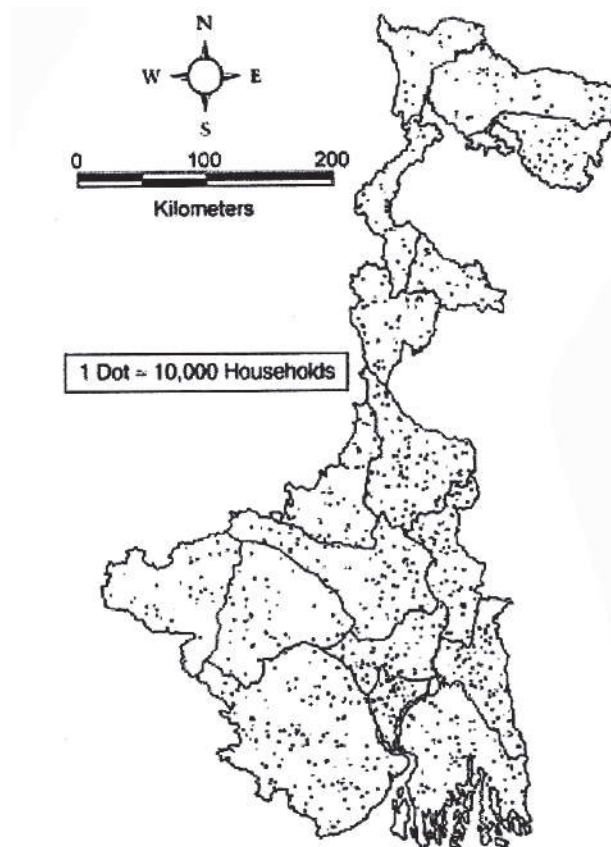

Fig. 55 : A Quantitative Dot Map

5.5 Choropleth Map

Choropleth maps are technically quantitative areal maps that show the spatial distribution of the intensity or density of an element with the help of a system of graded shading or colour, drawn following the boundaries of the administrative units. The basic principle is that the intensity of shading is directly proportional to the density of elements. These density maps, related as they are to the administrative units, display only average distributions. Hence, the grouping of a number of units under one average value implies distributional uniformity. This may be far from the real world picture for the broad average may mask a vast range of local- variations. Obviously, the more expansive the areal units, the more sweeping the generalisation presented in the map form.

The construction of a choropleth map is a 3-step process as follows:

1. The first step is the drawing of a worksheet with four columns-name of the unit (column 1), absolute value of an element (column 2), area (column 3) and the density obtained by dividing the absolute value by the area (column 4) and rows equalling the count of the administrative units.
2. The second step is the construction of a choropleth table showing the columns of the density classes, administrative units, shading system and remarks. The choice of the scale of densities may be based on arithmetical progression with uniform class interval, or geometrical progression with rapid increasing intervals, or quartile deviation or mean deviation or standard deviation of the dataset or any other criteria chosen by the performer that seems to better suit the urpose.
3. The third step involves the meticulous drawing of shades (of either line or colour) following the administrative boundaries as per the choropleth table(Fig. 36)

Worksheet – 1 for Computation of Population Density

District	Population (P)	Area (A: sq km)	Density (P/A: persons/sq km)
A	1609172	3,149	511
B	3401173	6,227	546
C	2479155	3,387	732
D	2441794	3,140	778
E	1503178	2,219	677
F	3290468	3,733	881
G	5866569	5,324	1102
H	3015422	4,545	663
I	6895514	7,024	982
J	4604827	3,927	1173
K	8934286	4,094	2182
L	5041976	3,149	1601

Worksheet – 2 for Choropleth Mapping

Density Class	Districts	Shading Systems	Remarks
501 - 750	A,B,C,E,H	Lightest	Very Low
751 - 1000	D,F,I	Light	Low
1001 - 1500	G,J	Medium	Moderate
1501 -2000	L	Deep	High
2001 -2500	K	Deepest	Very High

Choropleth maps are the basic tools of human geographers. The smaller the administrative unit, the more is the map precision. Intervals should be wisely chosen depending more on experience rather than on the theoretical character of distribution.

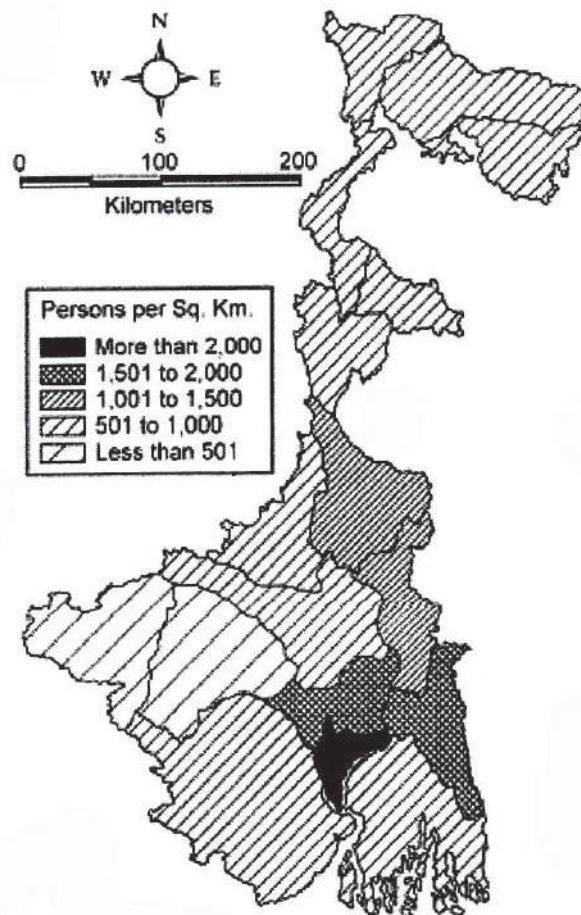

Fig. 36 : A Choropleth Map

5.6 Summary

From this unit we have learnt about the different tyhpes of dot map and choropleth map and their representation. These maps show interval data as colour or shade.

Unit-6 □ Preparation of Thematic Maps: Proportional Squares, Proportional Pie Diagrams, Dots and Spheres

Structure

6.0 Objectives

6.1 Introduction

6.2 Diagrammatic Maps

6.3 Proportional Squares Map

6.4 Proportional Pie Diagrams

6.5 Dots and Spheres

6.6 Summary

6.0 Objectives

- To study about the various schematic diagrams.
-

6.1 Introduction

Various schematic diagrams such as proportional squares, proportional pie diagrams, dots and spares are used for preparation of thematic maps.

6.2 Diagrammatic Maps

These maps, as the name suggests, show the representation of statistical data over the-map by means of suitable graphs and diagrams. These are also called thematic maps. The principles and procedures of such mapping are:

- i) the centres of circles and spheres must correspond to the exact site of the place or to the areal centres of the administrative units,
 - ii) the base of any graph or of a bar, rectangle, square, triangle or cube should be placed at the exact centre of the region or at any point to be so selected that it may lie, as far as practicable, within the limits of the area concerned. For this purpose the scale of representation should be thoughtfully chosen and
 - iii) if, in spite of all considerations, diagrams of contiguous administrative units appear to overlap, they should be drawn sequentially for places in the ascending order of size. The smaller ones must be clearly visible while the larger ones may be allowed to be partly consumed or eclipsed.
-

6.3 Proportional Squares Map

A proportional squares map comprises a series of squares proportional in size to the quantities they represent. Its construction is based on the principles that:

1. Area of a square (A) for an item is directly proportional to the quantity of the item (Q) it represents.
2. The area scale for the proportional squares is: a square of one unit area represents a quantity, q

Area of square, $A = x^2$ (x = side of a square)

The scale for the square diagrams should be chosen in such a way that individual squares are not too large or too small for the base map. A proportional scale is diagrammatically represented with at least three squares corresponding roughly to the largest, smallest and median values of the distribution.

Side of a square is computed as: $x = \sqrt{Q}$

Worksheet for Proportional Square Map

District	Quantity (Q)	$x = \sqrt{Q}$	Scale (s) (d = x / s: cm)	Side of Square (cm)
A	9579	97.87	1 cm to 50	1.96
B	9012	94.93		1.90
C	8901	94.35		1.89
D	7890	88.83		1.78
E	6789	82.40		1.65
F	5678	75.35		1.51
Proportional Scale	5000	70.71		1.41
	7500	86.60		1.73
	10000	100.00		2.00

Square diagrams are of two types:

- i) simple square diagrams where data with only one component is available and each square represents a single value and

- ii) compound square diagrams where the data comprise more for one component and each square is proportionately divided into rectangular segments to show its constituent parts.

When maps are not available these are drawn on the same baseline with uniform intervening space. Colours or shades may be applied for visual appeal. In compound square diagrams, percentage values instead of absolute values may be evaluated and used to subdivide the squares. The squares afford ready information concerning proportions and facilitate arithmetic comparisons.

The diagrammatic representation of the data mentioned in the worksheet has not been displayed. The Fig. 37 is a map for data set of Bankura District. The map prepared to show block-wise female population distribution of the district by proportional squares. A complete map should show the name of C.D. Blocks also.

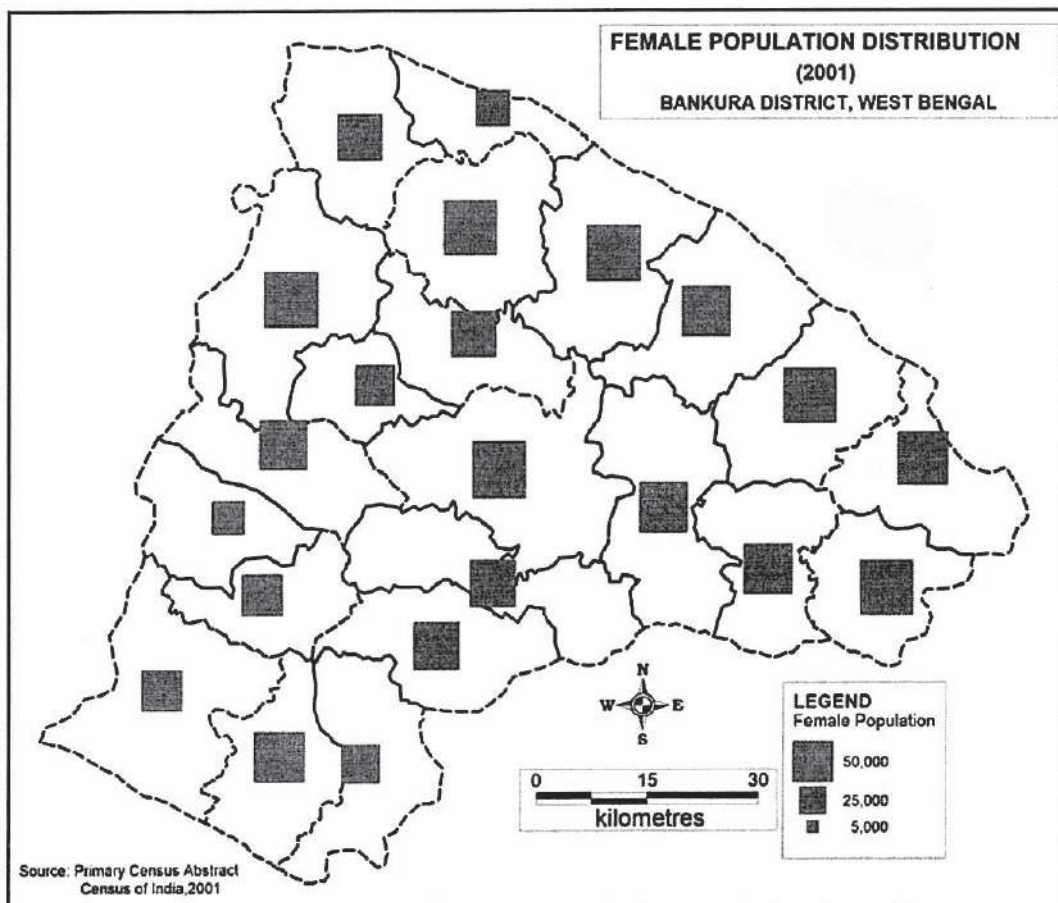

Fig. : Proportional Square Map

6.4 Proportional Pie Diagrams

Pie diagrams are also called compound circle diagrams or wheel diagrams or pie charts. It is used when the data comprises more than one component within a circle and is proportionately divided into angular segments to show its constituent parts. Area of the circle is proportional to the total while its segments are proportional to the total angular value at the centre of the circle, i.e., 360° .

$$\text{Area of a circle, } A = \pi \times r^2$$

The construction of circle diagrams is based on the principle that the area of a circle (A) for a quantity to be represented (Q) is directly proportional to the total quantity it represents.

$$\text{Radius of a circle is computed as: } r = \sqrt{\frac{Q}{\pi}}$$

The angular segments (s) for the constituent items ($i = 1, 2, 3, \dots$) are found by the formula:

$$\theta = \frac{360^\circ}{T} \times i$$

Worksheet – 1 for Proportional Pie Diagrams

District	Quantity (Q)	$r = \sqrt{\frac{Q}{\pi}}$	Scale (s)	Radii of Circle (r/s cm)
A	9579	55.22	1 cm to 15	2.76
B	9012	53.56		2.68
C	8901	53.23		2.66
D	7890	50.11		2.51
E	6789	46.49		2.32
F	5678	42.51		2.13
Proportional Scale	5000	39.89		1.99
	7500	48.86		2.44
	10000	56.42		2.82

Worksheet – 2 for Proportional Pie Diagrams

District	Total Production (Q)	Aus	Aman	Boro
A	9579 360°	1234 46°23'	6543 245°54'	1802 67°43'
B	9012 360°	2112 84°22'	5678 226°49'	1222 48°49'
C	8901 360°	998 40°22'	6745 272°48'	1158 46°50'
D	7890 360°	1122 51°12'	4425 201°54'	2343 106°54'
E	6789 360°	889 47°08'	4321 229°08'	1579 83°44'
F	5678 360°	1008 63°55'	3087 195°43'	1583 106°22'

The scale for the circle diagrams is carefully selected so that individual circles are not too large or too small for the base map. A proportional scale must be diagrammatically represented with at least three circles corresponding roughly to the largest, smallest and median values of the distribution. A worksheet is drawn showing the computations in detail. Colours or shades may be applied for an effective visual toning. When maps are not available, they should be drawn touching the same baseline with uniform intervening spaces or they must be centred at the particular place or at the areal centre of the administrative unit.

A separate worksheet is drawn to show the angular segments for each subdivision of the items and their total must be checked in a separate column. The drawing of the angular segments for each circle must start from a fixed line (either the radius drawn due west or north) and the respective order of drawing should be maintained throughout. A well planned legend of colours or shades must be drawn for the divisions of the main item. To afford ready information about proportions, percentage values corresponding to the angular segments, may be written on the outside or inside of its boundary as well.

The diagrammatic representation of the data mentioned in the worksheet has not been displayed. The Fig. 38 is a Map for data set of North 24 Parganas district.

North 24 Parganas District, W.B.

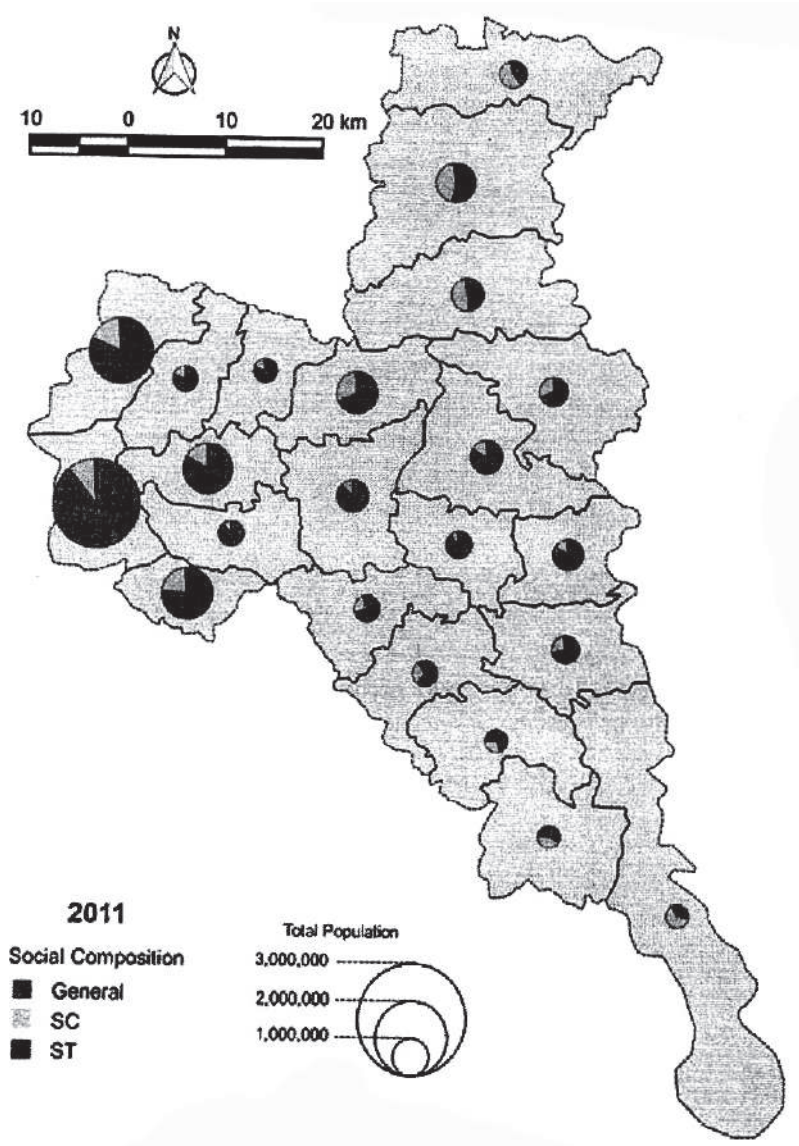

Fig. 38 : Proportional Pie Diagrams

6.5 Dots and Spheres

Dot-and-Sphere map is used to show the distribution of both rural settlements and urban settlements of a region. The postulate is that rural settlements are distributed all over the region and is comfortably shown by 'quantitative dots' with a suitably chosen 'dot scale' (Fig. 39). As cities contain urban population, proportional spheres are used to show its huge volume. (*Dot map has been discussed in the previous section in detail*).

Spheres are 3-dimensional diagrams comprising a series of spheres proportional in size to the quantities they represent. The construction of sphere diagrams is based on the principle that the volume of a sphere (V) for a quantity (Q) to be represented is directly proportional.

$$\text{Therefore, } V = \frac{4}{3} \pi r^3$$

The statement, a sphere of one unit volume represents a quantity, q, forms the volume scale for the spheres.

$$\text{Therefore, radius of a sphere is given by: } r = \sqrt[3]{\frac{3V}{4\pi}}$$

Worksheet for Proportional Sphere Diagrams

City Population, 2011 (V)	Urban	$\sqrt[3]{\frac{3V}{4\pi}}$	Scale (s)	Radii of Sphere (d=r/s:cm)
A	99579	28.75	1 cm to 20	1.44
B	159012	33.61		1.68
C	589901	52.02		2.60
D	1017890	62.40		3.12
E	336789	43.16		2.16
F	55678	23.69		1.18
Proportional Scale	50000	22.85		1.14
	100000	28.79		1.44
	1000000	62.03		3.10

The scale for the sphere diagrams should be carefully chosen so that individual spheres are not too small or too large for the base map. When maps are not available they should be drawn touching the same baseline with uniform intervening spaces; otherwise they must be centred at the particular place or at the areal centre of an administrative unit. A proportional scale must be diagrammatically represented with at least three spheres corresponding roughly to the largest, smallest and median values of the distribution. A worksheet must be neatly drawn to show the computations in detail. Graticule should be drawn or shading should be made carefully on the surface of the spheres to produce a 3-dimensional effects. Fig. 40 is an example of sphere effected by shading and Fig. 41 effected by the drawing of graticule.

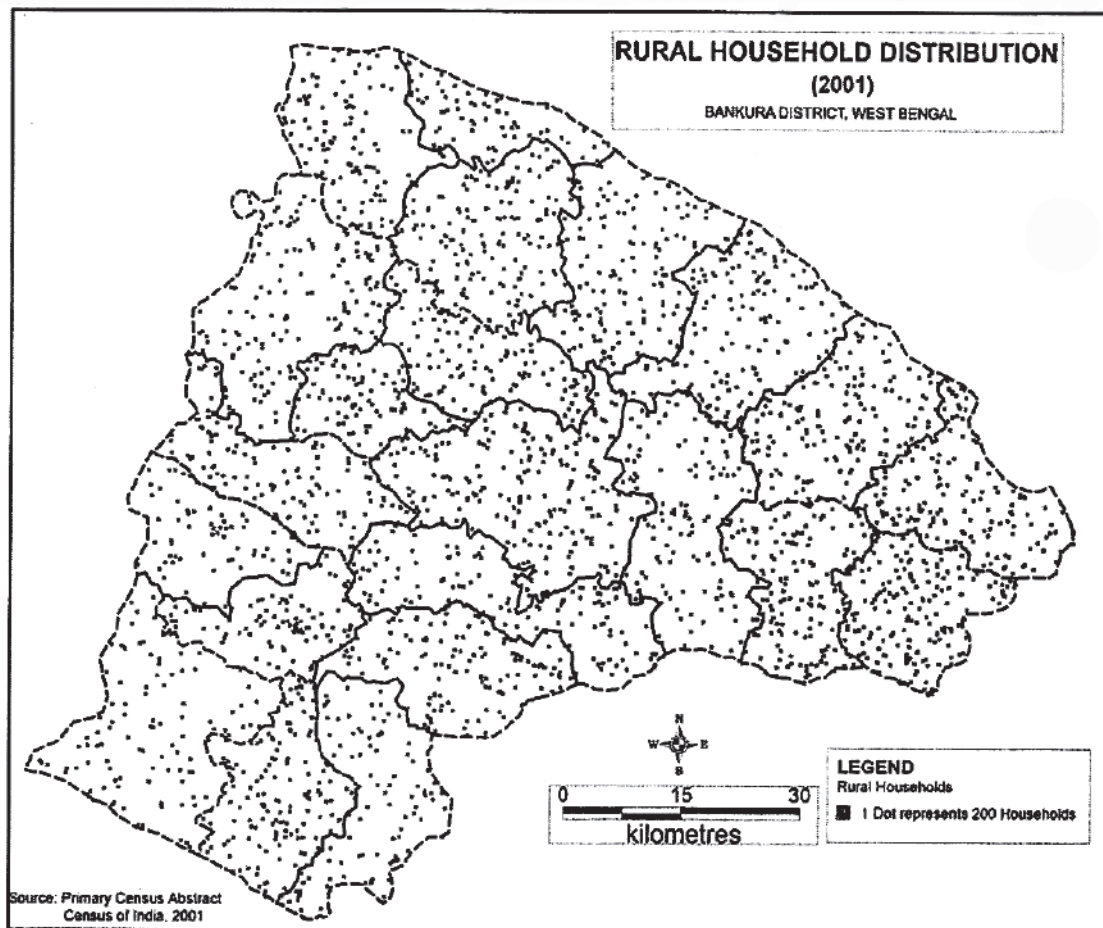

Fig. 39 : Quantitative Dot Map

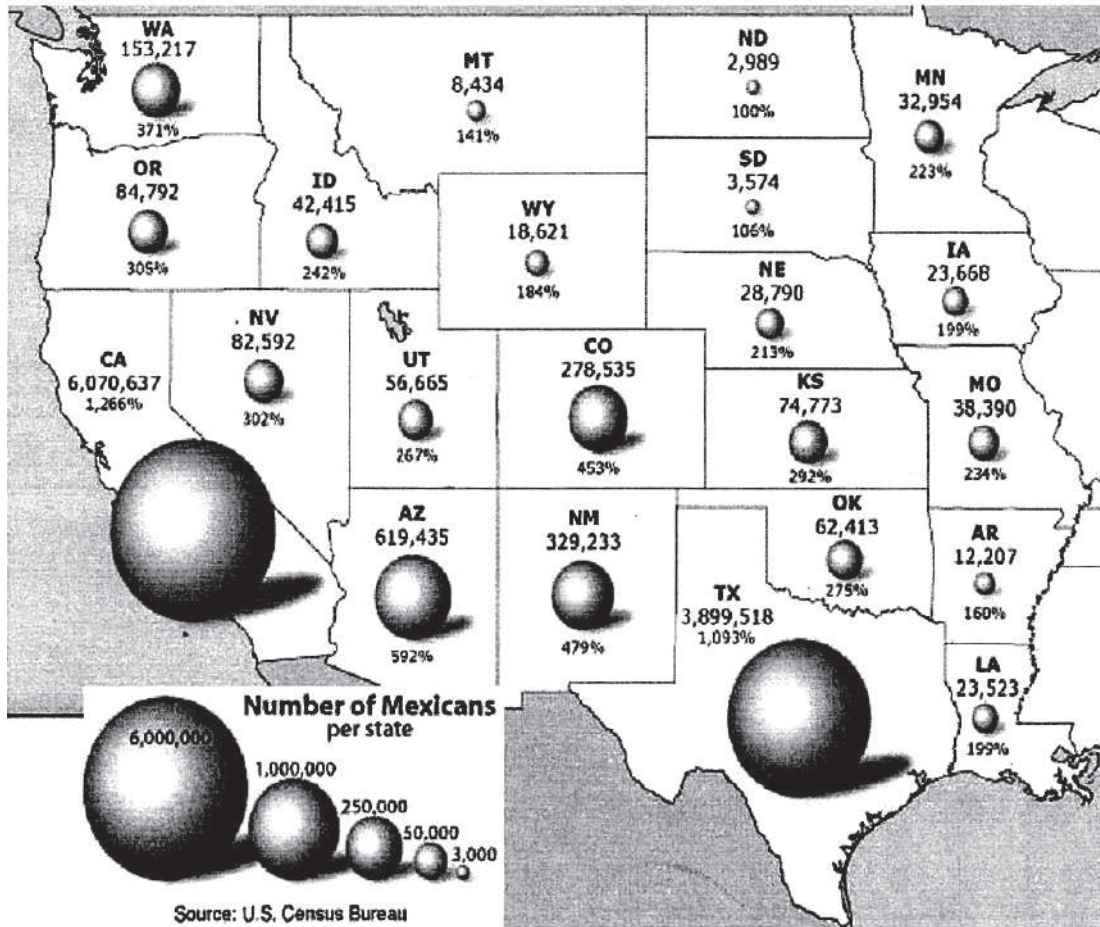

Fig. 40 : Proportional Sphere Map



Fig. 41 : Proportional Sphere Diagrams

6.6 Summary

This unit gives a quick overview of the relative size of data without the use of scales. The are simple symbols used to represent data for location.

Unit - 7 □ Traverse Survey using Prismatic Compass

Structure :

- 7.0 Objectives**
- 7.1 Introduction**
- 7.2 Prismatic Compass**
- 7.3 Bearing of a Line**
- 7.4 Local Attraction**
- 7.5 Magnetic Declination**
- 7.6 Whole Circle and Reduced Bearings**
- 7.7 Fore and Back Bearings**
- 7.8 Traverse Survey**
- 7.9 Observations with Prismatic Compass**
- 7.10 Traversing by a Prismatic Compass**
- 7.11 Procedure**
- 7.12 Correction of Bearings**
- 7.13 Checks on Closed Traverse by Angles**
- 7.14 Plotting the Traverse**
- 7.15 Adjustment of Closing Error**
- 7.16 Sources of Errors**
- 7.17 Precautions**
- 7.18 Summary**

7.0 Objectives

- Learners will come to know about the traverse survey.
- To study about prismatic compass.

7.1 Introduction

Surveying is needed for making accurate map of the earth's surface. It is defined as the art of taking such measurements as will determine the relative positions of points on the surface of the earth so that the size and shape of a portion of the

earth's surface may be ascertained and delineated on a map or plan. Obviously, it is a process of determining the positions of points on a horizontal plane. Contrary to this, the term levelling concerns the determination of the relative positions of points on a vertical plane. In a more comprehensive sense, surveying includes levelling.

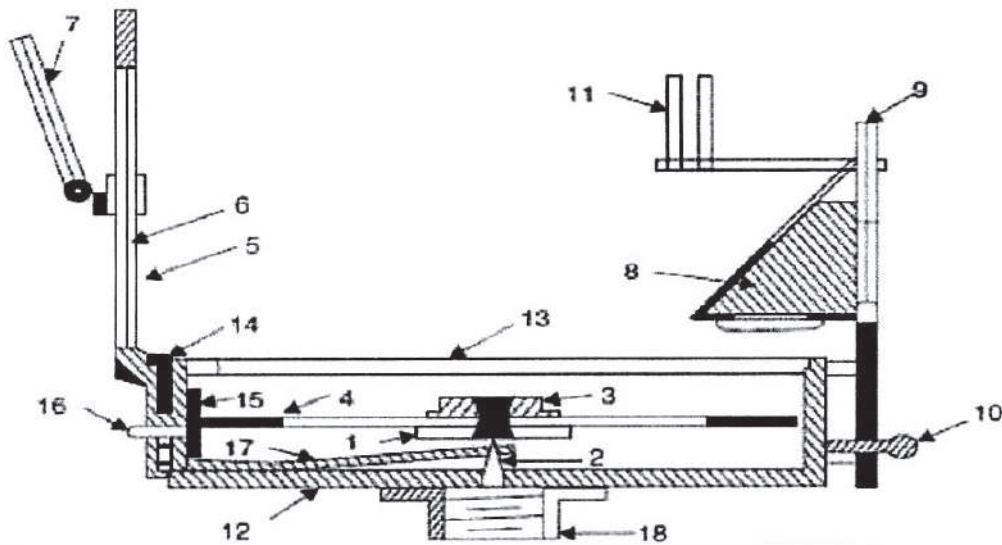

- | | |
|------------------------------|------------------------------|
| 1. Needle | 10. Focussing stud |
| 2. Pivot | 11. Dark Sunglasses |
| 3. Agate cap | 12. Box |
| 4. Graduated disc | 13. Glass cover |
| 5. Slit metal frame | 14. Litting pin |
| 6. Horse hair | 15. Light Spring |
| 7. Mirror | 16. Brake pin or knob |
| 8. Reflecting prism with cap | 17. Litting lever |
| 9. Eye vane | 18. Support to fit on tripod |

Fig. 42

7.2 Prismatic Compass

It is the most commonly used compass (Fig. 42) to find the magnetic bearing of a line. It consists of a circular box (85-110 mm diameter) with a glass cover, in the

centre of which a magnetic needle is balanced on a sharp pointed steel pivot with the help of an agate cap. The needle carries an aluminium ring with graduations in degrees and half degrees, which are written in an inverted style. The object vane and the focussing stud for the prism are fitted at diametrically opposite points. The former consists of a hinged metal frame in the centre of which a horse hair or a fine wire is stretched. When it is folded on the lid, it presses the lifting pin separating it from the pin. The oscillation of the needle can be quickly checked by the inward pressing of the brake pin fitted at the base of the vane. A reflecting prism (right angled isosceles type) with a sighting slit at the top of the perpendicular side is fixed to the focussing stud. On the base, a prism cap is fitted with a turnable screw and dark glasses are sometimes provided to reduce the luminosity of the object. The object vane is sometimes provided with an adjustable mirror to sight the object more accurately. The prismatic compass is normally mounted on a light wooden tripod with a ball-socket joint.

7.3 Bearing of a Line

It is the horizontal angle which the line makes with a reference direction or meridian, always measured clockwise from the line of reference. The bearing of a line (Fig. 43) may be:

- (i) **true bearing** or **azimuth**, if the reference line is a geographical meridian (i.e., the line passing through the given point and the geographical north and south poles),
- (ii) **magnetic bearing**, if the reference line is the magnetic meridian, passing through the given point and the magnetic north and south poles and
- (iii) **arbitrary bearing**, if the reference line is any line fixed and conceived on the ground during actual survey.

7.4 Local Attraction

It refers to the deflection of a magnetic needle caused by external disturbances induced by the proximity of magnetic substances.

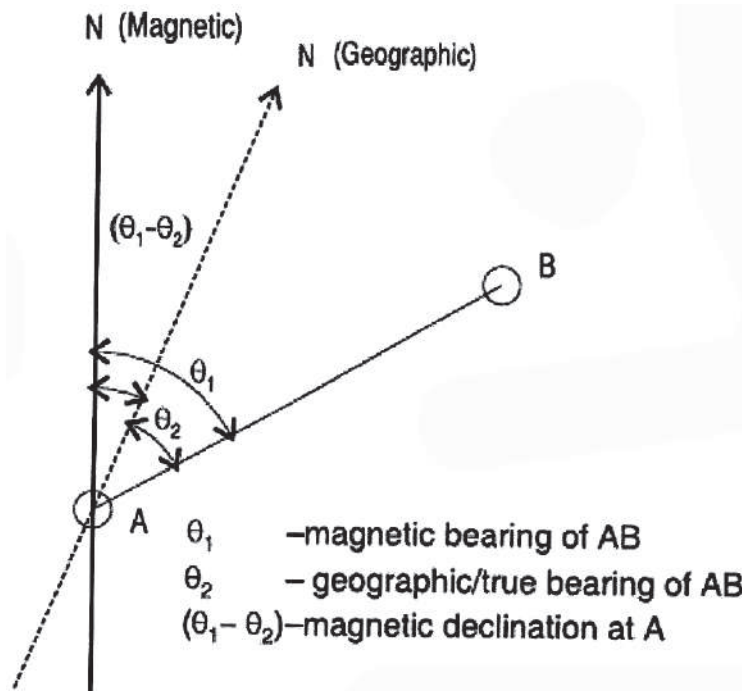

Fig. 43

7.5 Magnetic Declination

The horizontal angle which the magnetic meridian through a place makes with the geographical meridian through the same place, is called the magnetic declination (Fig. 43). It depends upon the latitude of the place and undergoes diurnal, annual, secular and irregular variations. It is used to determine the true bearing of a line from the equation:

$$\text{True Bearing} = \text{Magnetic Bearing} \pm \text{Magnetic Declination}$$

(‘+’ when the declination is East and ‘-’ when the declination is West.

Stations

These are the ground points defined by the nodes of triangles or junctions of a traverse.

7.6 Whole Circle and Reduced Bearings

Whole circle bearing (WCB) refers to the bearings expressed in whole circle system. In this, the bearing of a line is always measured clockwise from the north

line. The resultant amount may take any value between 0° and 360° . In contrast, the reduced bearing (RB) of a line refers to the bearings expressed in a quadrantal system in which it is measured as a horizontal angle from either the north or the south line (whichever is closer) towards either the east or the west line (whichever is closer). The magnitude of reduced bearing may take any value between 0° and 90° . In designating such bearings, quadrants are essentially mentioned.

7.7 Fore and Back Bearings

The fore or forward bearing of a line (Fig. 44) refers to that which is measured in the direction of the progress of the survey, while the bearing taken in the opposite direction is called back or backward bearing and are related by the equations:

$$\text{Back Bearing} = \text{Fore Bearing} \pm 180^\circ$$

(‘+’ if $\text{FB} < 180^\circ$ and ‘-’, if $\text{FB} > 180^\circ$)

or, $\text{Back Bearing} \sim \text{Fore Bearing} = 180^\circ$

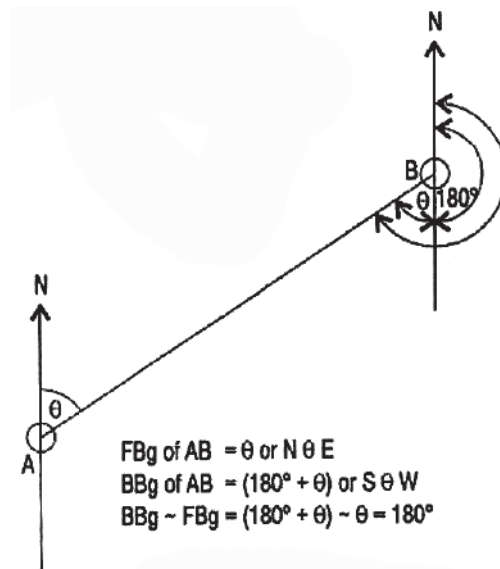

Fig. 44

7.8 Traverse Survey

A traverse consists of a series of related points or stations which, when connected by angular and linear values, form a framework. Therefore, a traverse survey is one in which the points of the traverse frame are plotted from the measurements of the

lengths and bearings (directions) of the series of connected lines. The lengths are usually measured with a tape while directions by a prismatic compass. The purpose is to control the subsequent details. The accuracy of the control survey must be superior to that of the subsidiary survey in general. A traverse may be of two types (Fig. 45) :

- 1) **closed**, when a complete circuit is made, i.e., the initial and final points coincide and
- 2) **open**, when the traverse framework does not form a closed polygon.

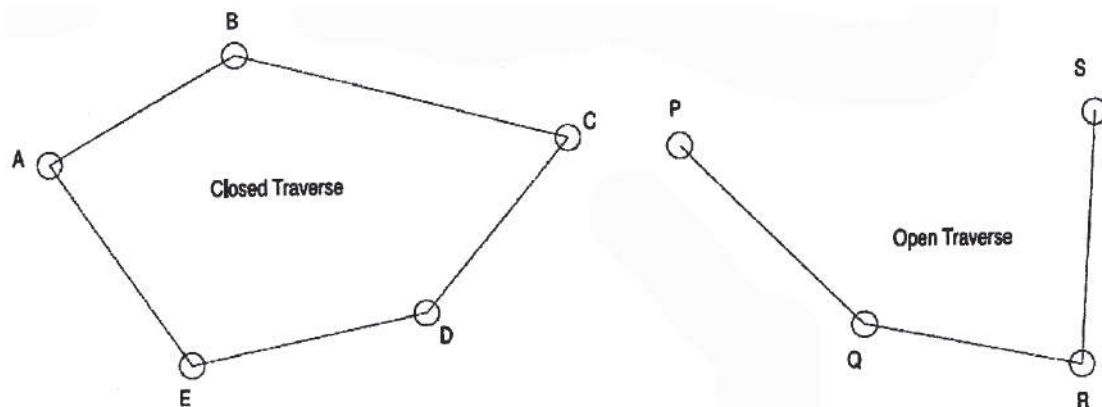

Fig. 45

7.9 Observations with Prismatic Compass

1. Set up the prismatic compass over a station at your convenient height.
2. The instrument must be exactly overhead the ground station. To do this, a plumb bob is suspended from the bottom centre of the instrument to touch the head of the vertical ground pin.
3. Unfold the object vane and also the eye vane.
4. Level the instrument either by hand or by using a round pencil so that the compass ring moves freely.
5. Rotate the instrument so that the line of sight (i.e., the line joining the centre of the eye piece and the horse hair) joins the station with the ranging rod held vertically over another station.

6. Look through the eye piece and take the reading in degrees and minutes at the intersection of the horse hair) ranging rod with the compass ring.

Note: As the least count of the circular scale is $0^{\circ} 30'$, readings are all in full degrees or may contain a term of $30'$ only.

7.10 Traversing by a Prismatic Compass

Loose needle traversing, as it is called, is mainly applied in reconnaissance or exploratory surveys. It is most advantageous because:

- (i) surveying is quick,
- (ii) each line is independent,
- (iii) the bearing of a line can be observed at any point along the line.

However, lack of accuracy and vulnerability to local attractions lead to different sources of errors which are the common demerits of such surveys. The instruments and accessories required are: a prismatic compass, a tripod, a plumb bob, a tape, a set of pins and ranging rods.

7.11 Procedure

- i. Ranging rods are to be fixed at all the stations marked by pins with tags.
- ii. A rough sketch of the traverse is then drawn on the field book and the date, time, place and instrument number are recorded.
- iii. Distances of the lines are then measured with a tape and noted in the field book.
- iv. At each station, the prismatic compass is carefully centred and levelled. From each station, the bearings of the two connected lines are then observed and recorded in the appropriate columns as forward bearings (measured in the direction of survey) and backward bearings (measured in the opposite direction of survey) either in the form of reduced or whole circle bearings.

Field Book
Closed Traverse Survey by Prismatic Compass

Place:
Inst.No.:

Date:
Time:

Line	Length (ft)	Observed Bearing		Difference (d)	Error (d-180°)	Error/2	Corrected Bearing		Remarks
		Fore	Back				Fore	Back	
AB	33.1	40°00'	219°00'	179°	-1°	-0°30'	39°30'	219°30'	i. all stations locally attracted.
BC	35.3	95°30'	276°30'	1a1°	+1°	+0°30'	96°00'	276°00'	
CD	36.4	208°30'	25°30'	183°	+3°	+1°30'	207°00'	27°00'	ii. Survey done clockwise
DA	42.2	282°30'	104°30'	178°	-2°	-1°00'	2as°00'	103°30'	

7.12 Correction of Bearings

The observed bearings are first corrected by adjusting the local attractions of the stations. The error can easily be detected from the difference of the fore and back bearings of a line. This difference should be exactly 180° and any deviation from this indicates local attraction at both ends of the line. The correction of bearings may be done as follows:

When all the stations are locally attracted, difference between the bearings of none of the lines is 180°. Therefore, all the stations are affected by local attraction. Correction is made by equally distributing the error at both ends. The amount of error, therefore, may vary along the two lines from a single station. This is the demerit of this system in general. The general rules of correction are:

1) If e (or error) is negative, deduct $\frac{e}{2}$ from the smaller readings and add $\frac{e}{2}$ to the larger one.

2) If e is positive, deduct $\frac{e}{2}$ from the larger readings and add $\frac{e}{2}$ to the smaller one.

7.13 Checks on Closed Traverse by Angles

For a closed polygon, the following checks may be applied:

Sum of the internal angles = $(2n - 4) \times 90^\circ$ (where n = number of sides in the polygon).

7.14 Plotting the Traverse

The traverse is normally plotted by parallel meridian method. In this, distance and the corrected fore bearing of each line are considered. At first, a map scale is selected and the ground distances are reduced. A small straight line is drawn vertically to represent the magnetic meridian. On it a point A is first marked and then the fore bearing of the first line (AB) is plotted with the help of a protractor and its length is marked off; thus the position of station B is fixed. Through B another line parallel to the magnetic meridian at A is drawn and the position of station C is similarly plotted with the help of the length and bearing of the line BC. The process is repeated at each station until all the lines are drawn (Fig. 46).

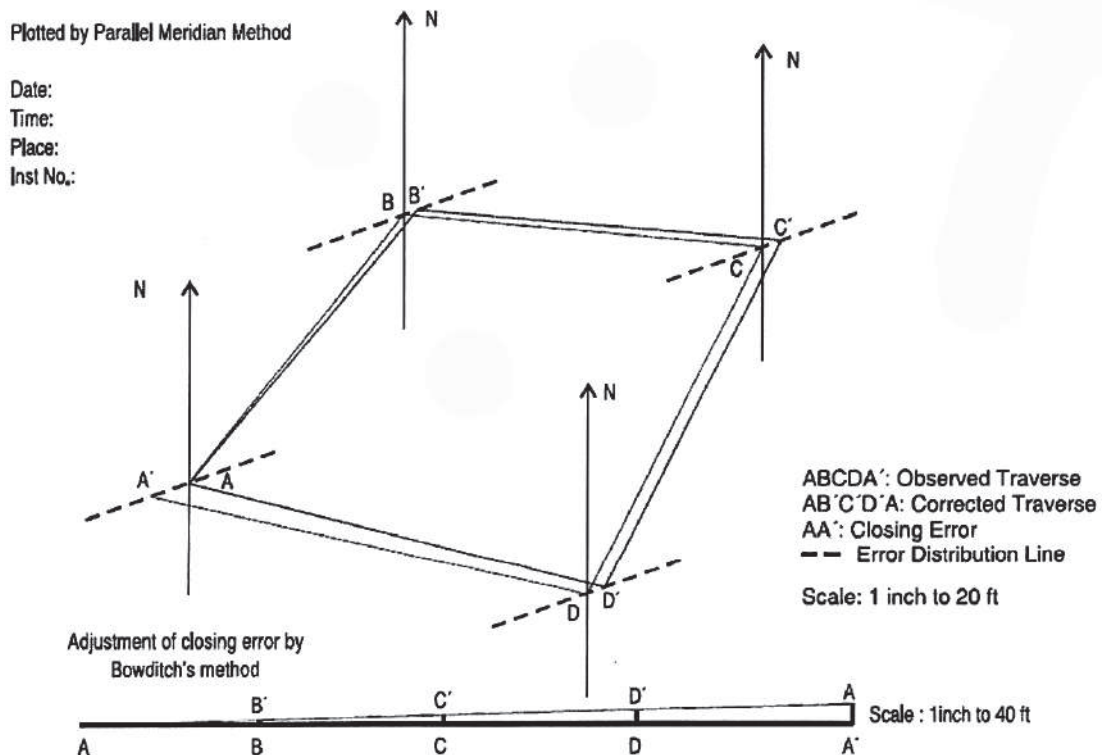

Fig. 46

7.15 Adjustment of Closing Error

After plotting the closed traverse data, there are often errors. The final point does not coincide with the initial point. This error is called closing error. To make

the traverse consistent, the closing error must be distributed by adjusting the lengths and bearings following either the Bowditch, Wilson or Smirnoff methods. Of these methods, the Bowditch method is more widely used because of its simplicity. It is based on the principle that the magnitude of error is proportional to the square root of distance. The closing error is distributed graphically by shifting each station by an amount proportional to the distance from the initial point parallel to the direction of the closing error. To do this, a straight line is drawn horizontally and the points are marked off with their reduced distances. At the closing point (A'), a perpendicular straight line is drawn and the amount of closing error (AA') is measured off. The top of this line is joined to the starting point (A) on the horizontal line and from each point on the horizontal line perpendiculars are drawn. These perpendicular segments (BB', CC', DD', etc.) are the proportionate closing errors to be distributed at the respective points. At each point on the plotted traverse, small straight lines parallel to the direction of closing error (error distribution line) are drawn. Then on each of these, respective closing errors are measured off and the corrected or adjusted points (B', C', D', etc.) are marked. These are then successively joined by straight lines to produce the corrected traverse in the form of a closed polygon (AB' C 'D' ... A).

7.16 Sources of Errors

The common sources of errors in a prismatic compass traversing are instrumental, observational due to manipulation and sighting, and external influences. Instrumental errors may be of several types, such as, the needle is not perfectly straight or is sluggish with some lost magnetism, the needle may not be freely moving, the pivot is dull and bent, the plane of sight is not vertical, the line of sight is not passing through the centre of the graduated circle, the vertical hair is loose and thick, etc. Manipulation and sighting errors may be due to improper centering and levelling, imperfect bisection of the station with eye piece and horse hair, and carelessness in reading the graduated circle and recording the data properly in the field book. External influences like magnetic changes in the atmosphere, variations in magnetic declinations and local attractions due to the proximity of the magnetic substances may result in plottable errors in compass traversing.

7.17 Precautions

Before setting, the instrument should be tested so that the instrumental errors can be eliminated at the outset. The instrument should be centred and levelled carefully. Before taking a reading, the compass should be precisely oriented so that the centre of the eye piece, the centre of the graduated circle, the horse hair and the ranging rod when held vertically over a station are all collinear and coplaner. The reading should be taken in the direction of increasing values only after the needle comes to a standstill. Magnetic substances of any sort should be avoided.

7.18 Summary

Surveying is indeed the most important technique of determining the terrestrial or three-dimensional positions of points and the distances and angles between them. It has been an element in the development of the human environment since the beginning of recorded history.

Unit-8 □ Levelling and Contouring using Dumpy Level and Prismatic Compass

Structure

- 8.0 Objectives**
- 8.1 Introduction**
- 8.2 Dumpy Level**
- 8.3 Observations with Dumpy Level**
- 8.4 Levelling Staff**
- 8.5 Profile Levelling**
- 8.6 Arithmetic Check**
- 8.7 Contouring**
- 8.8 Methods**
- 8.9 Procedure**
- 8.10 Computation**
- 8.11 Interpolation of Contours**
- 8.12 Sources of Errors**
- 8.13 Precautions**
- 8.14 Summarys**

8.0 Objectives

- To learn about the levelling and contouring methods.
- To learn about the precautions while levelling and contouring.

8.1 Introduction

Levelling concerns the determination of the relative positions of points on a vertical plane. In a more comprehensive sense, surveying includes levelling.

8.2 Dumpy Level

Of the levelling instruments, it is the most simple, compact and stable one. The levelling head consists of a tribrach and a trivet with three arms each carrying a foot or a levelling screw. A telescope is rigidly fixed to its supports fitted to the spindles which are attached to the central hollow of the tribrach. The rotation of the telescope around the vertical axis is regulated by a clamp and a slow motion tangential screw. The telescope contains an eye piece, diaphragm, focussing screw, sighting knob and object glass. On its body, two level tubes (long and cross) are fixed in perpendicular directions(Fig. 47)

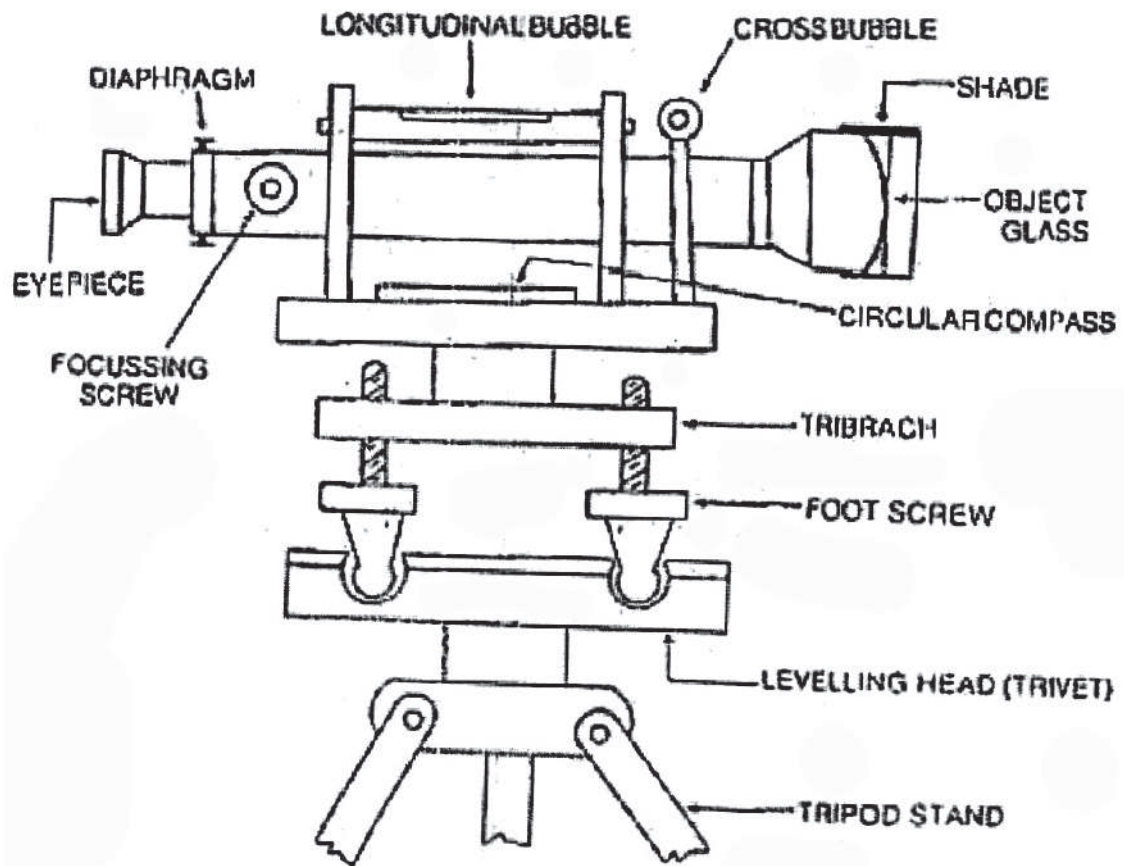

Fig. 47

8.3 Observations with Dumpy Level

1. Set the Dumpy level over a station.
2. Release the clamping screw and rotate the telescope to make it parallel to a line joining any two foot screws.
3. Rotate these two foot screws with both hands simultaneously either inward or outward until the bubble in the level tube is centred.
4. The telescope is then rotated to make it perpendicular to the line joining the previous two foot screws. Rotate this 3rd foot screw until the bubble in the level tube is centred.

5. The three foot-screws make an equilateral triangle. Step 2 to Step 4 is repeated twice separately for the remaining two sides of the triangle. This series of operations make the Dumpy level perfectly levelled at the given station.
6. Rotate the telescope until the line of collimation passes through a station with the staff held vertically over the station. Clamp the tangential screw and use slow motion tangential screw for precise sighting.
7. Look through the eye piece, adjust the focussing screw and take the required stadia reading on the staff.

Note: All readings on a metre-staff contain figures with three places after the decimal point and those on a foot staff contain figures with two places after the decimal point. A metre is divided into 200 alternate black and white lines of uniform thickness and spacing of 0.005 m and a foot is divided into 100 alternate black and white lines of uniform thickness and spacing of 0.01 ft.

A reading of 1.235 m = 1 is written in red on the right, = 2 is written in black on the left and there are 7 ($0.035 = 0.005 \times 7$) black and white horizontal lines between the 1.200 m mark and the middle stadia. Similarly, a reading of 5.64 ft = 5 is written in red on the right, = 6 is written in black on the left and there are 4 ($0.04 = 0.01 \times 4$) black and white horizontal lines between the 5.60 ft mark and the middle stadia.

8.4 Levelling Staff

It is made of either wood or aluminium and may have graduations either in feet or in metres. The staff is normally 75 mm wide, 18 mm thick and 4 m long. It can be folded or may have sop with telescopic arrangements. There is a brass cap at each end of the staff. In a foot staff, each foot is divided into 100 equal divisions while in a metre-staff, each metre is divided into 200 equal divisions. On its silver white face, the graduations are numbered in red and black while the smallest divisions are coloured black and white(Fig. 48)

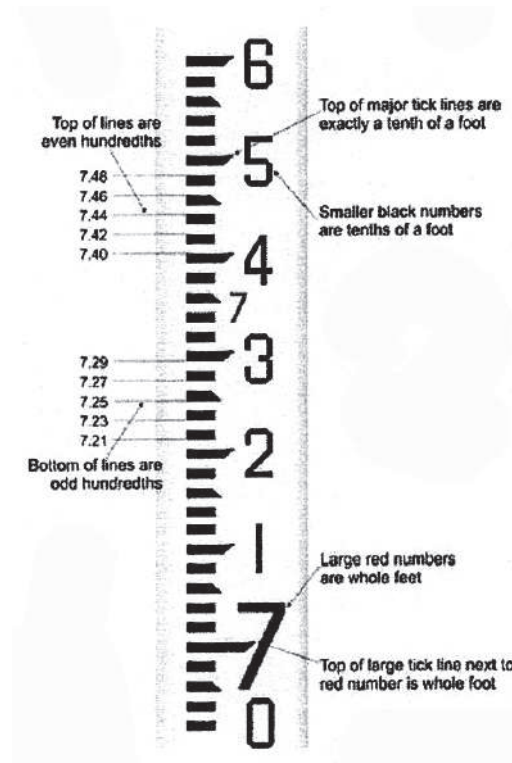

Fig. 48

8.5 Profile Levelling

To draw a profile between two given points on the ground, Dumpy level is the most useful instrument. This is called profile levelling that gives a clear idea of the nature of irregularities of the ground along a chosen line in a particular direction. The following are the steps of doing this:

1. A line is laid on the ground between two points, A and B and stations are demarcated at a regular interval of distance on it (for distance measurement, commonly a measuring tape is used). Pins with Station Tags are placed at all the stations.
2. A Dumpy level is set up at a place from where all the stations are visible. The minimum distance of the closest station should be more than or equal to 5 m (it will help clear sighting of the Staff and taking measurements).

3. The instrument is then perfectly levelled using its three foot screws.
4. A staff is placed vertically over the first station.
5. The telescope is now turned to the staff with focussed eye-piece. The focussing screw on the telescope is rotated for clear visibility of the staff, when the line of sight intersects the staff.
6. Measurements on the staff at the intersection of the 'middle stadia' is then read accurately and recorded in the field book.
7. The first reading is recored as BSR (Back Sight Reading) and the last reading as FSR (Fore Sight Reading). All other readings are written as ISR (Intermediate Sight Readmg).
8. BM of the given station is noted to compute the 'height of collimation' and RL of a station is computed from it.

The formulae are:

$$\text{Height of Collimation} = \text{BSR} + \text{BM}$$

$$\text{RL of a station} = \text{Height of Collimation} - \text{ISR} / \text{FSR}$$

9. The RLs are then plotted against the distances on a suitable scale by a line graph to find the nature of the ground(Fig. 49). The most important condition for this is that the vertical scale (VS) must be ten times that of the horizontal scale (HS). For example, if the horizontal scale is 1 inch to 10 ft, vertical scale will be 1 inch to 1 ft. Similarly, if HS is 1 cm to 5m, VS is 1cm to 0.5 m. To accommodate all the RLs, a datum is chosen nearest to the minimum RL value.

Note: There are situations when all the stations may not be visible from a particular station. In such cases, the instrument is shifted to another place and the BSR for the second set-up is taken at the station with FSR in the previous set-up.

Field Book

PROFILE LEVELLING BY DUMPY LEVEL

Date:
Time:

Instrument No.
Place:

Instrument at	Station	Distance (m)	BSR (m)	ISR(m)	FSR (m)	Ht of Collimation	RL	Remarks
X	A	0	1.235			26.560	25.325	
	1	10		1.350			25.210	
	2	20		1.785			24.775	
	3	30		1.810			24.750	
	4	40		2.010			24.550	
	5	50	1.750		1.560	26.750	25.000	BM,CP
y	6	60		1.955			24.795	
	7	70		1.985			24.765	
	8	80		2.220			24.530	
	B	90			2.255		24.495	
Arithmetic Check			2.985		3.815			
				-0.830			-0.830	

8.6 Arithmetic Check:

Sum of BSR – Sum of FSR = Last RL – First RL = - 0.830 m

LONGITUDINAL PROFILE ALONG A LINE : AB
BY
DUMPY LEVEL

Date:
 Time:

Instrument No.
 Venue:

Fig. 49

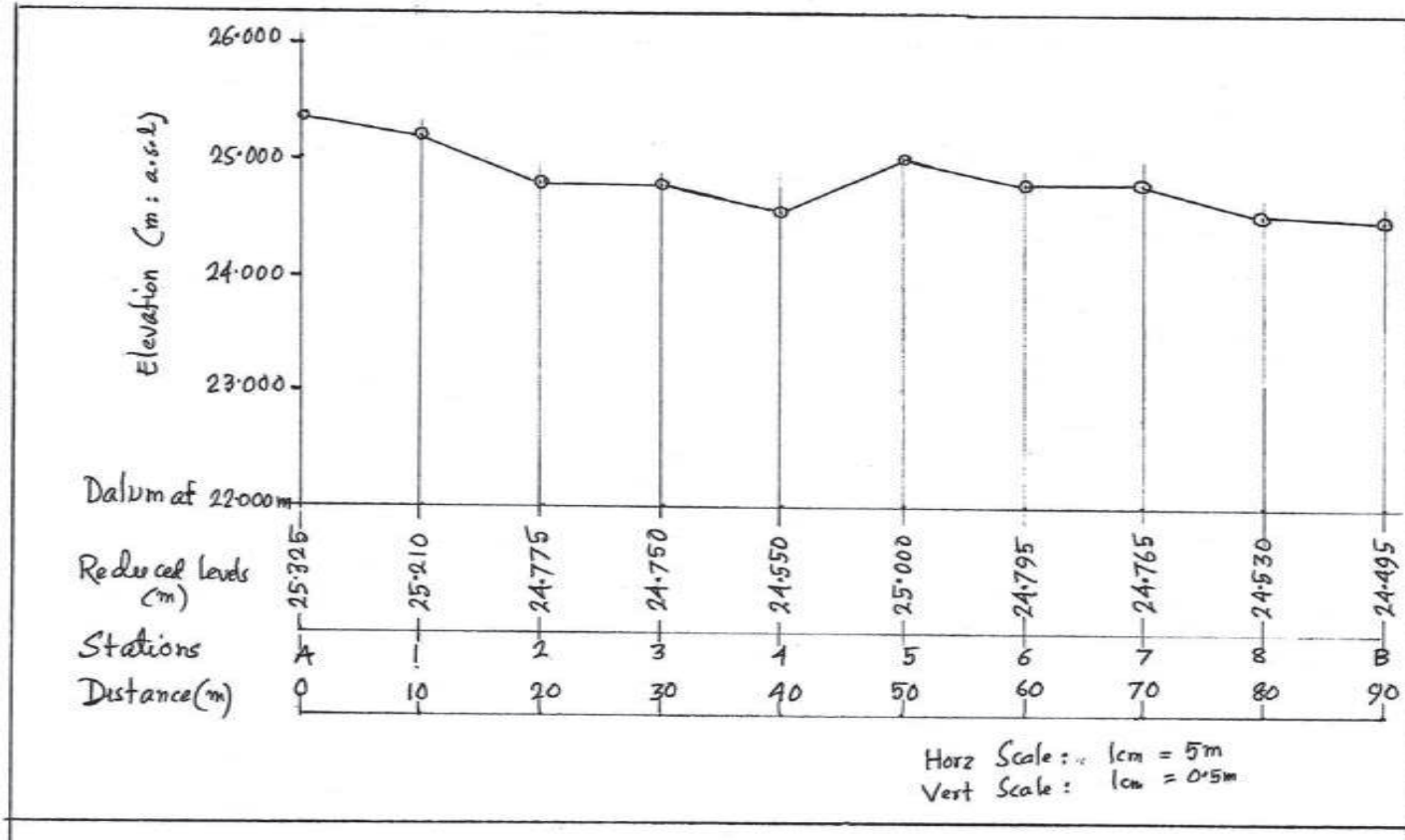

8.7 Contouring

A contour is an imaginary line joining places with equal elevation above the sea level. Technically, it is defined as the line of intersection of a level surface with the surface of the ground. The vertical distance between two consecutive contours is called contour interval while the horizontal distance between the two is known as horizontal equivalent. Normally, the nature of the ground, the purpose and extent of the survey, the map scale and the amount of time and financial investment involved, together determine the contour interval. The smaller the map scale, the larger is the contour interval and the smaller the interval, the larger is the amount of field and office works. Contour maps are useful for engineering, hydrological and geomorphological studies.

8.8 Methods

The preparation of a contour plan or map requires—

- 1) first, *surveying and plotting the traverse*: If the area to be contoured is not very extensive, a traverse may be so laid that it consists of a set of radial lines diverging from the apparently highest or lowest point of the area.

The lengths and directions of each line may be fixed by prismatic compass survey. Stations may be taken at a regular distance apart on each line.

- 2) second, *levelling survey* to find the reduced levels of all the points on the traverse and
- 3) finally, the *interpolation of the contours* on the traverse plan.

The equipment for levelling consists of a level (commonly a Dumpy level), a tripod, a levelling staff, a tape and a well laid out and neatly drawn field book for recording the staff readings, distances and field notes.

8.9 Procedure

- 1) The instrument is first set up at a convenient height and at a place from where a maximum number of stations can be sighted.
- 2) The instrument is then perfectly levelled with the help of foot screws and level tube.

- 3) The telescope is then directed towards the staff held vertically over the station (within or outside the traverse) with a known reduced level (Bench Mark). The eye piece and the object are focussed properly and the staff reading for the middle stadia is taken and the first reading is entered as a back sight reading (BS).
- 4) Similarly the staff readings for all the visible stations are taken successively. The last reading of the set up is entered as a fore sight reading (FS) while all others as intermediate sight readings (IS).
- 5) The instrument is then shifted to some other convenient position(s) from where the readings of the remaining stations (not covered in the first set up) can be taken. In this set up, the first reading is taken on the staff held at the last station of the former set up. It is certainly a back sight reading. This station is called a change point (CP).
- 6) Following the same procedure, staff readings are then taken on the remaining stations.

8.10 Computation

The reduced levels of the stations can be calculated easily using collimation method. In this, the reduced levels are evaluated by subtracting the staff readings from the corresponding height of collimation. The common rules are:

- 1) $HC = BS + RL \text{ of BM}$
- 2) $RL \text{ of a Station} = HC - IS \text{ or FS}$
- 3) For a new set up, i.e., at change points, new heights of collimation are evaluated as
- 4) $HC \text{ of a CP} = BS + RL \text{ of the CP}$

Arithmetical checks are done to avoid any ambiguity and confusion. The common checks are:

$$\Sigma IBS - \Sigma FS = \text{Last RL} - \text{First RL}$$

Field Book
Determination of Reduced Levels by Dumpy Level

Date:	Time:	Place :	Inst. No. :	<i>Collimation Method</i>		
Stations	Staff Reading (ft)			Height of Collimation (ft)	Reduced Levels (ft)	Remark
	BS	IS	FS			
A	09.87			34.87	025.00	BM
B		04.56			030.31	
C		02.32			032.55	
D	08.76		1.23	42.40	033.64	CP
E		06.18			036.22	
F		03.57			038.83	
G	11.65		1.94	52.11	040.46	CP
H		05.83			046.28	
I			1.57		050.54	
Σ	30.28	22.46	4.74		333.83	

Arithmetical Check :

$$\Sigma BS - \Sigma FS = 30.28 - 4.74 = 25.54; RL_1 - RL_A = 50.54 - 25.00 = 25.54$$

8.11 Interpolation of Contours

- 1) With the help of distance and bearing, the traverse or the radial lines are first plotted on a selected scale.
- 2) Stations are the marked on the lines.
- 3) Stations are then labelled with their RLs
- 4) From the range of RLs, contours are then selected at a suitable interval. Interpolation of contours between two RLs on a line may be done either by eye estimation or by arithmetical calculation.
- 5) Location of a desired contour depends on the amount of relief between the points with respect to the distance and the direction of rise or fall.

- 6) Through the interpolated points of identical elevation, freehand smooth lines are drawn to represent the desired contours(Fig. 50).

CONTOUR PLAN BY DUMPY LEVEL SURVEY

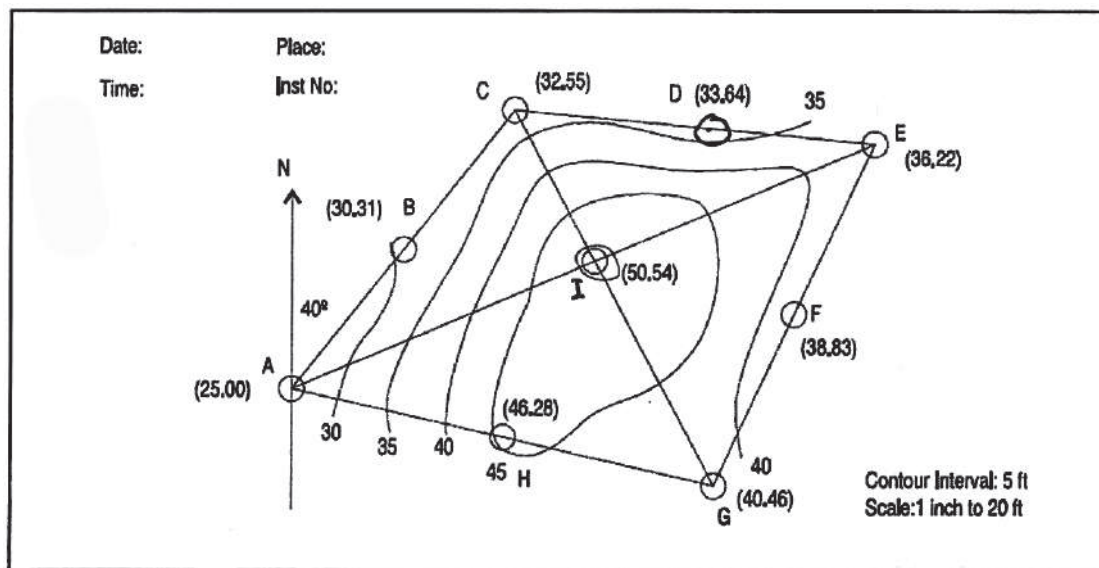

Fig. 50

8.12 Sources of Errors

The common sources of errors in contouring are instrumental, observational and natural. (*Sources of errors in compass traversing have already been discussed*). However, in levelling operations, the instrumental errors consist of a defective foot screw, a defective bubble tube, imperfect adjustment of the telescope and bubble, a faulty focussing tube, erroneous divisions on the staff and so on. Improper and careless levelling, parallax in sighting, non-verticality of the staff and mistakes in reading and recording the values in the field book are the common observational errors. The natural sources of errors are high wind, high sun, high temperature, curvature and refraction.

8.13 Precautions

At every stage, surveying should be done very carefully. Special precautions should be taken while levelling the instrument, reading the staff, holding the staff

vertically over the stations, taking back sight reading at the last station of the former set up in case of change points, checking the office work in detail, etc.

8.14 Summary

This unit gives the learners an overall idea about the levelling and contouring methods. levelling is a process of determining the height of one level relative to another.

Glossary / Keywords

1. Scale
2. RF
3. Ratio Scale
4. Comparative Scale
5. Linear Scale
6. Vernier Scale
7. Primary Division
8. Secondary Division
9. Tertiary Division
10. Least Count
11. Vernier Constant
12. Main Scale
13. Vernier
14. Precision of Scale
15. Map Projection
16. Projection Plane
17. Generating Globe
18. Developable Surface
19. Standard Parallel
20. Latitude
21. Longitude
22. Parallels
23. Meridians
24. Great Circle

25. Constant of cone
26. Rhumb Line
27. Loxodrome
28. Orthodrome
29. Equidistant projection
30. Equal Area projection
31. Orthomorphic Projection
32. Azimuthal Projection
33. Aphyllactic Projection
34. Planar Projection
35. Conical Projection
36. Cylindrical Projection
37. Polar Projection
38. Zenithal Projection
39. Radial Scale
40. Tangential Scale
41. Diagram
42. Line
43. Point
44. area
45. Volume
46. Line diagram
47. Multiple line diagram
48. Polygraph
49. Band graph
50. Log-log graph

51. Semi-log graph
52. Bar diagram
53. Multiple bar diagrams
54. Compound bar diagrams
55. Bar scale
56. Vertical bar diagrams
57. Horizontal bar diagrams
58. Pyramid
59. Percentage bar diagrams
60. Point data
61. Period data
62. Spatial data
63. Geographical data
64. Isarithm
65. Isoline
66. Isometric line
67. Isogram
68. Isontic line
69. Natural breaks
70. Isopleth map
71. Trend surface map
72. Area data
73. Dot map
74. Qualitative dot map
75. Quantitative dot map
76. Dot scale

77. Choropleth map
78. Graded shading
79. Thematic map
80. Diagrammatic map
81. Flowline map
82. Choroschematic map
83. Choropleth map
84. Chorochromatic map
85. Colour patch map
86. Proportional scale
87. Proportional square maps
88. Proportional pie diagrams
89. Proportional sphere maps
90. Area of a Square
91. Area of a Circle
92. Volume of a sphere
93. Surveying
94. Traverse
95. Closed traverse
96. Open Traverse
97. North line
98. Magnetic bearing
99. True bearing
100. Whole circle bearing
101. Reduced bearing
102. Closing error

-
103. Plan
 104. Map
 105. Prismatic compass
 106. Ranging rod
 107. Local attraction
 108. Magnetic declination
 109. Fore bearing
 110. Back bearing
 111. Levelling
 112. Dumpy level
 113. Collimation line
 114. Axis of the telescope
 115. Horizontal line
 116. Vertical line
 117. Plumb line
 118. Level line
 119. Level surface
 120. Bench Mark
 121. Reduced Level
 122. BSR
 123. ISR
 124. FSR
 125. CP
 126. Contour
 127. Interpolation

Reference and Further Readings

1. Anderssen R S Osborne M R (ed. 1970) : Data Representation, Queensland University Press
2. Balchin W G V and Lewis WV (1945): The Constrction of Distribution Maps, *Geography*, 30(3), pp91
3. Bugayevskiy L Mand Synder P (1995): Map Projections - a reference manual, London: Taylor and Francis
4. Clark D (1963): Plane and Geodetic Surveying for Engineers, Vol. I & II, Constable, London
5. Cole J P and King CAM (1970): Quantitative Geography, John Wiley & Sons, NY
6. Cuff D J and Mattson MT (1982): Thematic Maps - their design and production, Methuen, London
7. Deetz CH and Adams OS (1934): Elements of Map Projection, *USCGS Spl. Bull.68*, pp117-136
1. Dent B D (1990): Cartography - thematic map design, William Brown Pub., Dubuque, IA
2. Garnier BJ (1963): Practical Works in Geography, Edward Arnold Pub., London
3. Hinks AR (1921): Map Projections, Cambridge University Press
4. Kanetkar T P and Kulkarni S V (1965): Surveying and Levelling, Part - I & II, AVG Prakashan, Pune
5. Keates JS (1973): Cartographic Design and Production, Longman, London
6. Kelllaway, G, P (1957): Map Projections, Methuen
7. Kraak M J and F Ormerling (1996): Cartography- visualisation of Spatial Data, Longman, Harlow
8. Mainwaring J (1960): An Introduction to the study of Map Projections, McMillan & Co., London
9. Maling DH (1973): Co-ordinate Systems and Map Projections, George Phillip & Sons Ltd., London

10. Money DC (1969): An introduction to Mapwork and Practical Geography, UT Press Ltd, London
11. Monkhouse F J and Wilkinson HR (1967): Maps and Diagrams - their compilation and construction, Methuen, London
12. Pearson F (1990): Map Projection - theory and application, Boca Raton, Florida
13. Raisz E (1938): General Cartography, McGraw Hill Book Co., NY
14. Robinson AH et al (1995): Elements of Cartography, John Wiley & Sons, NY
15. Ross Mackay J (1955): An Analysis of isopleth and Choropleth Intervals, *Economic Geography*, 31(1), pp71-81
16. Sarkar A (2013): Practical Geography-A Systematic Approach, Orient BlackSwan, New Delhi
17. Shepherd, F.A. (1968): Surveying Problems and Solutions, Edward Arnold Pub., UK
18. Singh R L (1979): Elements of Practical Geography, Kalyani Pub., New Delhi
19. Slocum TA (1999): Thematic Cartography and Visualization, Prentice-Hall Inc, NJ
20. Snyder JP (1987): Map Projections - a working manual, USGS, USG PO, Washington DC
21. Steers, J, A (2003): A Introduction to the Study of Map Projections, Text Book Publishers
22. Winterbotham HJ L (1934): Dots and Distribution, *Geography*, 19(3), pp 211-213
23. Wolf PR and RC Brinker (1989): Elementary Surveying, Harper & Row Pub., NY

QUESTIONS

1. Define Scale.
2. What are the different types of scale?
3. Compare ratio scale and statement scale.
4. Compare graphical scale and ratio scale.
5. What are the advantages of ratio scale?
6. What are the advantages of comparative scale?
7. What is linear scale?
8. What do you mean by 'precision of scale'?
9. What are 'primary divisions'?
10. What are 'secondary divisions'?
11. What is 'least count of scale'?
12. Define 'vernier constant'.
13. Why the 'diagonal' scale is so named?
14. What is vernier reading?
15. Define map projection.
16. What is a projection plane?
17. What is a generating globe?
18. What is a developable surface?
19. Define 'standard parallel'.
20. Define latitude of a place.
21. Define longitude of a place.
22. What are parallels of latitude?
23. What are 'meridians of longitude'?
24. Define a 'great circle'.

25. How many great circles can be drawn on a globe?
26. Define 'constant of a cone'.
27. What are Rhumb Lines?
28. What is meant by 'loxodrome'?
29. What are orthodromes?
30. What are equidistant projections?
31. What are equal area projections?
32. What are orthomorphic projections?
33. What are azimuthal projections?
34. What are aphylactic projections?
35. What are planar projections?
36. What are conical projections?
37. What are cylindrical projections?
38. What are polar projections?
39. What are zenithal projections?
40. Define radial scale.
41. Define tangential scale.
42. State the principles of PZ Stereographic Projection.
43. State the principles of Simple Conical Projection with 1 Standard Parallel.
44. State the principles of Bonne's Projection.
45. State the principles of Cylindrical Equal Area Projection.
46. State the principles of Mercator Projection.
47. State the properties of PZ Stereographic Projection.
48. State the properties of Simple Conical Projection with 1 Standard Parallel.
49. State the properties of Bonne's Projection.
50. State the properties of Cylindrical Equal Area Projection.

51. State the properties of Mercator Projection.
52. What are graphs?
53. What are diagrams?
54. What is a line graph?
55. What are polygraphs?
56. What are band graphs?
57. What is a log-log graph?
58. What is a semi-log graph?
59. What are bar diagrams?
60. What are multiple bar diagrams?
61. What are compound bar diagrams?
62. Define bar scale.
63. What are vertical bar diagrams?
64. What are horizontal bar diagrams?
65. What is a pyramid?
66. What are percentage bar diagrams?
67. Which data are suitable for line graphs?
68. Which data are suitable for polygraphs?
69. Which data are suitable for band graphs?
70. Which data are suitable for bar diagrams?
71. Which data are suitable for multiple bar diagrams?
72. Which data are suitable for compound bar diagrams?
73. Which data are suitable for pyramids?
74. What is 'point data'?
75. What is 'period data'?
76. What is 'spatial data'?

77. What is 'geographical data'?
78. Define isarithm.
79. Define isoline.
80. Define isometric line.
81. Define isogram.
82. Define isontic line.
83. What are natural breaks?
84. What are isopleth maps?
85. What are trend surface maps?
86. Which data are suitable for isopleth maps?
87. What are the advantages of isopleth maps?
88. What is meant by 'area data'?
89. What are 'dot maps'?
90. What are qualitative dot maps?
91. What are quantitative dot maps?
92. Define 'dot scale'.
93. State the principles of placing 'dot' on a map.
94. What are 'choropleth maps'?
95. How does choropleth maps differ from chorochromatic and choroschematic maps?
96. What is meant by 'graded shading'?
97. What is 'area data'?
98. What are area symbols?
99. What are volume symbols?
100. Define a 'thematic map'.
101. What are diagrammatic maps'?

102. What are flowline maps?
103. What are choroschematic maps?
104. What are chorochromatic map?
105. What are colour patch maps?
106. What is meant by 'proportional scale'?
107. What are proportional square maps?
108. What are proportional pie diagrams?
109. What are proportional sphere maps
110. What is the area of a square?
111. Give the radius, circumference and area of a circle.
112. Give the radius, surface area and volume of a sphere.
113. Define surveying.
114. Define a traverse.
115. What is a closed traverse?
116. What is an open traverse?
117. Define 'North line'.
118. Define bearing of a line.
119. What is magnetic bearing?
120. What is true bearing?
121. What is whole circle bearing?
122. What is reduced bearing?
123. What is meant by 'closing error'?
124. Define a 'Plan'
125. Define a 'Map'.
126. Name the parts of a Prismatic compass.
127. What is a Ranging rod?

128. What is meant by 'local attraction'?
129. What is 'magnetic declination'?
130. What is Fore bearing of a line?
131. What is 'Back bearing of a line'?
132. How a traverse survey is done with a Prismatic compass?
133. How the local attraction is adjusted?
134. What is the check for bearings of a line?
135. What is the check for included angles of a traverse?
136. What are the precautions to be taken in a traverse survey by Prismatic compass?
137. Define levelling.
138. What are the parts of a Dumpy level?
139. How a Dumpy level is perfectly levelled?
140. Define collimation line.
141. What is 'axis of the telescope'?
142. Define horizontal line.
143. Define vertical line.
144. What is plumb line?
145. What is 'level line'?
146. What is 'level surface'?
147. What is Bench Mark (BM)?
148. What is Reduced Level (RL)?
149. What is BSR?
150. What is ISR?
151. What is FSR?
152. What is Change Point (CP)?

153. Define a contour.
154. What is meant by 'interpolation'?
155. What are instruments used for contour survey?
156. What are the sources of error in Dumpy level survey?
157. What are the precautions necessary in Dumpy level survey?

Notes

Notes
